

Graphic Panel

# LP-S044

## USER MANUAL



Thank you very much for selecting Autonics products.

**For your safety, please read the following before using.**



# Preface

Thank you very much for selecting Autonics products.





Please familiarize yourself with the information contained in the **Safety Precautions** section before using this product.

This user manual contains information about the product and its proper use, and should be kept in a place where it will be easy to access.

# User Manual Guide



- Please familiarize yourself with the information in this manual before using the product.
- This manual provides detailed information on the product's features. It does not offer any guarantee concerning matters beyond the scope of this manual.
- This manual may not be edited or reproduced in either part or whole without permission.
- A user manual is not provided as part of the product package. Please visit our home-page ([www.autonics.com](http://www.autonics.com)) to download a copy.
- The manual's content may vary depending on changes to the product's software and other unforeseen developments within Autonics, and is subject to change without prior notice. Upgrade notice is provided through our homepage.
- We contrived to describe this manual more easily and correctly. However, if there are any corrections or questions, please notify us these on our homepage

# User Manual Symbols

Symbol	Description
 <b>Note</b>	Supplementary information for a particular feature.
 <b>Warning</b>	Failure to follow instructions can result in serious injury or death.
 <b>Caution</b>	Failure to follow instructions can lead to a minor injury or product damage.
 <b>Ex.</b>	An example of the concerned feature's use.
※1	Annotation mark.

# Safety Precautions

- Following these safety precautions will ensure the safe and proper use of the product and help prevent accidents and minimize hazards.
- Safety precautions are categorized as Warnings and Cautions, as defined below:

 <b>Warning</b>	<b>Warning</b>	Cases that may cause serious injury or fatal accident if instructions are not followed.
 <b>Caution</b>	<b>Caution</b>	Cases that may cause minor injury or product damage if instructions are not followed.

## Warning

- In case of using this unit with machinery (Ex: nuclear power control, medical equipment, ship, vehicle, train, airplane, combustion apparatus, safety device, crime/disaster prevention equipment, etc) which may cause damages to human life or property, it is required to install fail-safe device.  
It may cause a fire, human injury or property loss.
- Do not use the Logic Panel where serious physical damage or production halt can be caused.  
It may cause a fire, human injury or property loss.
- In case using the Logic Panel touch switch for controlling, do not use the switch as an emergency switches or those related to safety that may cause physical injury or property damage in the event of a malfunction..  
It may cause a fire, human injury or property loss.
- In the event of LP defect or malfunction in the Logic Panel, an alternative circuit must be constructed on the exterior.  
It may cause a fire, human injury or property loss.
- Construct an emergency power-off circuit, safety circuit, or interlock circuit on the exterior of the Logic Panel.  
It may cause a fire, human injury or property loss.
- If an error occurs on the watchdog timer of the Logic Panel, the logic program will shut down automatically, so an alternative circuit must be constructed on the exterior.  
It may cause a fire, human injury or property loss.
- The overall system operation may malfunction due to an input error resulting from a failure in input signal detection; so an alternative circuit must be constructed on the exterior.  
It may cause a fire, human injury or property loss.
- For output signals that may cause a serious accident if the output section is damaged, a detection circuit and alternative circuit must be constructed on the exterior.  
It may cause a fire, human injury or property loss
- In case controlling other devices through Logic Panel communication, and there is a possibility of malfunction due to communication error, an alternative circuit must be constructed.  
It may cause a fire, human injury or property loss.

- When switching the mode to RUN mode, make sure that supply power to LP, I/O unit and load first. If not, output error or miss-operation may cause.  
It may cause a fire, human injury or property loss.
- Do not use the product in an area or an environment not specified in the manual.  
It may cause a fire, human injury or property loss.
- Do not connect, inspect or repair this unit when power is on.  
It may cause electric shock or a fire.
- Do not disassemble the product. Please contact us if it is required.  
It may cause electric shock or a fire.
- Please use the rectified power with insulation trans.  
It may cause electric shock or a fire.
- Do not use the power to the exceeded rated voltage.  
It may cause electric shock or a fire.
- This product uses lithium battery, do not disassemble or burn up it.  
It may cause an explosion or a fire.
- Wire properly after checking power terminal polarity.  
It may cause a fire or a malfunction.

**Caution**

- Please read all notes and cautions related to installation and wiring in the manual.  
It may cause electric shock or malfunction.
- Make sure the ground wire of Logic Panel is wired separately from the ground wires of other devices. Ground resistance must be less than  $100\Omega$ , and a lead wire of which sectional area is over  $1.25\text{mm}^2$  should be used.  
It may cause electric shock or malfunction.
- When connecting Logic Panel ports with communication port and constructing input/output, check the pin number and terminal block before connecting.  
It may cause a fire or malfunction.
- Please tighten bolt on terminal block with specified tightening torque.  
It may cause a short circuit, fire or a malfunction.
- Do not press the surface of the touch panel with sharp or hard objects.  
The touch panel may be damaged.
- Keep Logic Panel at the specified temperature.  
If stored at a temperature beyond the specification, LCD may be broken.
- Do not inflow dust or wire dregs into the unit.  
It may cause a fire or a malfunction.
- Do not use in an area with excessive humidity or temperature.  
It may shorten the life cycle of this unit or cause a malfunction.
- Do not close ventilating opening of this product.  
It may cause a malfunction due to increased inner temperature.
- Keep the product out of direct sunlight or excessive dust.  
It may shorten the life cycle of this unit or cause a malfunction..

- Do not use or store in a place with shock or vibration.  
It may shorten the life cycle of this unit or cause a malfunction.
- When liquid crystal from the broken LCD is smeared with skin, wash it for 15 minutes.  
If liquid crystal enters your eyes, flush it for 15 minutes and consult a medical specialist for more instructions.
- In cleaning the unit, do not use water or organic solvent. And use dry cloth.  
It may cause electric shock or a fire.
- Please separate as an industrial waste when discarding this unit.  
To change the battery, contact the store or an authorized technician.
- The manufacturer is not liable for damages that occur due to causes for which the manufacture is not responsible, regardless of manufacturer's prediction about customer's opportunity loss and damage from the unit malfunction, damages due to extraordinary situations, secondary damages, compensation for accident, damages on other product, and compensation for other process.
- Note that this device is KCC certified for commercial use. Make proper applications for the product.

**※ The specifications and dimensions of this manual are subject to change without any notice.**



# Table of Contents

	Preface iii	
	User Manual Guide.....	iv
	User Manual Symbols.....	v
	Safety Precautions.....	vi
	Table of Contents.....	ix
<b>1</b>	<b>Overview .....</b>	<b>13</b>
1.1	Logic Panel.....	13
1.2	Feature of LP.....	14
1.3	Ordering information.....	15
1.4	Specification.....	16
	1.4.1 General specification.....	16
	1.4.2 Performance specification.....	17
	1.4.3 LP basic specification.....	18
1.5	Communication .....	19
	1.5.1 Communication interface .....	21
1.6	Part description .....	21
1.7	Dimensions .....	22
<b>2</b>	<b>Installation .....</b>	<b>23</b>
2.1	LP installation .....	23
2.2	Power wiring .....	24
	2.2.1 Ground wiring.....	25
	2.2.2 Input wiring.....	26
	2.2.3 Output wiring.....	27
2.3	Battery replacement.....	28
2.4	Caution for using.....	28
<b>3</b>	<b>Device Construction .....</b>	<b>29</b>
3.1	Device element.....	29
3.2	Device range.....	31
	3.2.1 Bit device range .....	31
	3.2.2 Word device range .....	32
3.3	Application of UW, UB corresponding.....	32
<b>4</b>	<b>System Organization .....</b>	<b>33</b>
4.1	Stand-alone .....	33
4.2	Connection with controller.....	34
	4.2.1 1:1 organization.....	34
	4.2.2 1:N organization .....	35
	4.2.3 Heterogeneous organization .....	36
4.3	Universal organization.....	37
4.4	Connect with barcode, printer.....	38

4.5	Operation mode .....	39
4.5.1	Change operation mode .....	39
4.6	Program processing procedure .....	40
4.7	Connect with GP Editor .....	41
4.7.1	GP Editor configuration .....	42
4.8	Connect with SmartStudio .....	43
4.8.1	LP configuration .....	43
4.8.2	SmartStudio configuration .....	43
<b>5</b>	<b>Start up LP .....</b>	<b>45</b>
5.1	Checking list before supplying power .....	45
5.2	Operation order .....	46
<b>6</b>	<b>System Screen .....</b>	<b>47</b>
6.1	Organization of system screen .....	47
6.2	Operation of system screen .....	48
6.3	Monitoring .....	49
6.3.1	Device monitor .....	49
6.3.2	I/O monitoring .....	49
6.4	Set Environment .....	50
6.4.1	Language .....	50
6.4.2	PLC setting .....	51
6.4.3	Clock .....	55
6.4.4	Clear USER DATA .....	55
6.4.5	Menu call key .....	56
6.4.6	Buzzer .....	56
6.4.7	Opening time .....	57
6.4.8	Backlight .....	57
6.4.9	Battery .....	58
6.4.10	Contrast .....	58
6.5	Data View .....	59
6.5.1	Base screen .....	59
6.5.2	Window screen .....	59
6.5.3	Comment .....	59
6.5.4	Memory size .....	59
6.5.5	Model & Version .....	60
6.6	Set Function .....	61
6.6.1	Time switch .....	62
6.6.2	Print out .....	63
6.7	Set parameter .....	64
6.7.1	Filter .....	64
6.7.2	Interrupt .....	65
6.7.3	4 X 4 keypad .....	66
6.7.4	7 segment display .....	67
6.7.5	Synchronous serial .....	69
<b>7</b>	<b>User Screen .....</b>	<b>71</b>
7.1	Screen specification .....	71

7.2	Screen display object.....	72
7.3	Screen switching .....	73
7.4	Overlap window function.....	74
7.5	Device connection status display.....	76
<b>8</b>	<b>System Window .....</b>	<b>77</b>
8.1	Keypad type .....	77
8.2	Keypad organization .....	78
<b>9</b>	<b>Troubleshooting.....</b>	<b>79</b>
<b>10</b>	<b>Firmware update .....</b>	<b>81</b>
10.1	Firmware update by GP Editor .....	81
10.2	Firmware update by SmartStudio .....	83
<b>11</b>	<b>Repair and Check.....</b>	<b>85</b>
11.1	Battery change.....	85
11.2	Check.....	86
	11.2.1 General check .....	86
	11.2.2 Periodic check .....	86
<b>12</b>	<b>Appendix.....</b>	<b>89</b>
12.1	Self-diagnosis code table.....	89
12.2	ASCII code table.....	90
12.3	UW correspondence table.....	91



# 1 Overview

## 1.1 Logic Panel

Logic Panel (after referred to as LP) is the integrated device with HMI(Human Machine Interface) and PLC(Programmable Logic Controller) functions as one.

It is very effective to display visual interface about connected device's status and to control connected devices conveniently without additional device at limited space.

LP monitors control variables visually by LCD screen, switches the screen, sets the variable value by touching a touch screen, and controls the device directly by output port. The other controllers from LP is connected by serial communication and it is able to exchange mutual information.

The variable for controller is displayed by various methods as tag which is graphic object. For example, if the physical variable for monitoring is temperature, LP displays temperature as numeral by numeral input tag, or as trend graph with changes by time. LP screen consists of these graphic objects combinations.

GP Editor which is dedicated software for user defined screen data and SmartStudio which is for user defined data help create program and draw or edit screen. After editing screen data such as tag form, arrangement, and attribution in GP Editor, download these to LP and LP starts to monitor by screen data. You can programming PLC logic and monitor the operation in SmartStudio.

## 1.2 Feature of LP

- Compact structure  
LP realizes as one with power, PLC, HMI, I/O modules.
- Logic specification  
LP has 8000 step program capacity.  
It supports 28 basic instructions and 233 application instructions.
- Wide device range  
LP supports auxiliary device 10K Word, data device 10K Word and other several devices.
- Variable external I/O than equivalent product  
LP supports input 16 points/ output 16 point basically. (Terminal block connector, ribbon cable connector)
- Expansion function; external interrupt, matrix, 7Segment, synchronous communication, etc.  
Supports expansion function; external interrupt, matrix 16 key input, 7 Segment output, synchronous communication output, etc.
- Space saving and simple wiring  
Automation system with LP series saves install space and provides simple wiring.
- Cost saving for install and maintenance  
Automation system with LP series saves cost and time for install and maintenance.
- Product upgrade by web site  
We offer LP firmware, GP Editor, SmartStudio, protocol, language and font, various manuals at [www.autonics.com](http://www.autonics.com) to download conveniently.
- Monitoring function of other type controller  
By PLC connection port, LP monitors and controls the variable of additionally connected controller (PLC, etc).
- Communication between heterogeneous controllers  
You can connect other type controller to serial port separately.  
LP monitors two different controllers simultaneously and relays communication between two controllers.
- Multi monitoring function  
You can connect same type of several controllers.
- Supports multilingual  
LP supports Korean, English and the other languages are available for the later.
- Supports several font  
LP supports various bitmap font and vector font. You can select the desired font and use it.
- Multi communication port  
LP supports several communication port such as RS232C / RS422 serial communication port, USB HOST USB DEVICE, and Ethernet.  
Two serial ports of RS232C / RS422 are designated for the device connecting by software (PLC, computer, printer, barcode reader, etc). By supported communication type of connected device, select port to communication.
- Monitoring function for controller device  
Without designed data, LP menu is available for monitoring connectable controller device.
- Printer and barcode reader connection

You can print alarm list by connecting printer.  
It is able to read barcode by connecting barcode reader.

- Touch interface

It is able to input value in controller with touch switch on front screen.

### 1.3 Ordering information

Model	LP-S044-S1D0-C5T-A	LP-S044-S1D0-C5R-A	LP-S044-S1D1-C5T-A	LP-S044-S1D1-C5R-A
화면크기	4.4inch			
표시장치종류	STN LCD			
표현 색상수	MONO(Blue, White)			
전원전압	24VDC			
인터페이스	RS232C, RS422C 각 1 개		RS232C 2 개	
모듈형태	일체형			
I/O 구성	IN: 16 점, OUT: 16 점			
I/O 커넥터타입	터미널 블록 커넥터	리본케이블 커넥터	터미널 블록 커넥터	리본케이블 커넥터
확장기능타입	Type A 지원			

## 1.4 Specification

### 1.4.1 General specification

Model	LP-S044-S1D0-C5T(R)	LP-S044-S1D1-C5T(R)
Power supply	24VDC	
Allowable voltage range	90 to 110% of power supply	
Power consumption	Max. 3.6W	
Serial interface	Each of RS232C, RS422 (Asynchronous method)	Two of RS232C (Asynchronous method)
Real-time controller	RTC embedded	
Battery life time	3 years at 25°C	
Insulated resistance	Min. 100MΩ (at 500VDC megger)	
Ground	3rd grounding(Max. 100Ω)	
Noise immunity	The square wave noise (Pulse width 1 μs) by the noise simulator with ±0.5kV	
Withstanding voltage	500VAC (50/60Hz) for a minute	
Vibration	Mechanical	0.75mm amplitude at frequency of 10 to 55Hz (for a minute) in each of X, Y, Z directions for an hour
	Malfunction	0.5mm amplitude at frequency of 10 to 55Hz (for a minute) in each of X, Y, Z directions for 10 minutes
Shock	Mechanical	300m/s <sup>2</sup> (30G) X, Y, Z directions for 3 times
	Malfunction	100m/s <sup>2</sup> (10G) X, Y, Z directions for 3 times
Environment	Temperature	0 to 50°C, Storage: -20 to 60°C
	Humidity	35 to 85% RH, Storage: 35 to 85% RH
Protection	IP65F(for front panel)	
Accessory	Fixing bracket: 4 pcs, waterproof rubber ring, battery (included)	
Approval	CE	
Unit weight <sup>※1</sup>	Approx. 454g (Approx. 312g)	

※1: The weight in parentheses is only unit weight.

※Environment resistance is rated at no freezing or condensation.



## 1.4.2 Performance specification

Display performance			
LCD type	STN Blue Negative		
Resolution	240 X 80 dot		
Display area	112.8 X 37.6mm		
Color	MONO(Blue, White)		
LCD view angle	Within each 30° of top/bottom/right/left		
Backlight	White LED		
Brightness	Adjustable by software		
Graphic drawing performance			
Language ※1	Korean, English, Japanese, Chinese, Russian, Vietnamese, Portuguese		
Text	<ul style="list-style-type: none"> <li>•High resolution display up to 400 characters</li> <li>•6X8, 8X8 ASCII character, high quality view of numbers</li> <li>•8X16 ASCII character, 16X16 regional characters (1 to 8 times bigger for width, 0.5 to 5 times bigger for height)</li> </ul>		
Graphic drawing memory	384kB		
Number of user screen	500 pages		
Touch switch	Width 15 X Height 4 = Total 60		
Control performance			
Instruction	Basic instruction: 28, Application instruction: 220		
Program capacity	8K step		
Processing time	Average: 6 to 7 $\mu$ s/ step		
I/O control type	Batch processing		
Operation control mode	Repeated-doubling method, interrupt processing		
Device range	Refer to '3.2 Device range'		
Interface			
Communication interface	LP-S044-S1D0-C5T(R): Each of RS232C, RS422		
	LP-S044-S1D1-C5T(R): Two of RS232C		
Input specification		Output specification	
Input point	16 points	Output point	16 points
Insulation method	Photo coupler insulation	Insulation method	Photo coupler insulation
Voltage range	19.2 to 28.8VDC	Voltage range	19.2 to 28.8VDC
Rated input voltage	24VDC	Power supply	24VDC
Rated input current	Approx. 4mA	Max. load current	0.1A/1point, 1A/1COM
Input resistance	5.6 k $\Omega$	Max. voltage falling when ON	Under 0.2VDC

Response time	1ms	Response time	1ms
Common method	16 points / 1COM	Common method	16 points / 1COM

### 1.4.3 LP basic specification

Function		Description
MONITORING	DEVICE MONITOR	Monitors connected PLC device and changes the status
	I/O MONITORING	Monitors I/O state of LP-S044
SET ENVIRONMENT	LANGUAGE	Designates system language and character set
	PLC SETTING	Configures serial port for connecting between Editor and connected device, printer, barcode reader, or monitor
	CLOCK	Designates current time and date
	CLEAR USER DATA	Deletes GP DATA and LP DATA
	MENU CALL KEY	Designates the position for calling system setting menu
	BUZZER	Designates using buzzer or not
	OPENING	Set time for open screen when supplying power
	BACKLIGHT	Set off time for backlight as screensaver
	BATTERY	Displays battery remaining with percentage (%) and bar graph
	CONTRAST	Adjusts LCD screen contrast
DATA VIEW	BASE SCREEN	Displays user-defined base screen title and number
	WINDOW SCREEN	Displays user-defined window screen title and number
	COMMENT	Displays downloaded comment list in LP
	MEMORY SIZE	Displays total memory capacity and available memory capacity
	MODEL & VERSION	Displays current version of LP series and model name.
SET FUNCTION	DATA TRANSFER	Displays this menu during communicating (download/upload) between LP and GP Editor
	TIME SWITCH	Designates time switch
	PRINT OUT	Prints out alarm history with printer
SET PARAMETER	FILTER	Displays input filter value
	INTERRUPT	Displays external interrupt setting of input contact
	4 X 4 KEYPAD	Displays the data for controlling 4X4 keypad
	7 SEGMENT DISPLAY	Displays the data for controlling 4 digit segment

Function		Description
	SYNCHRONOUS SERIAL	Displays the data for synchronous serial setting

## 1.5 Communication

Depending on PLC model type, connections for PLC are different, therefore refer to 'GP, LP user manual for communication'.

Every device such as PLC is able to connect any RS232C or RS422 port. CH1, CH2 is designates in GP Editor.

- Connection of 1 PLC  
Connect PLC to a port and one of PC, printer, barcode reader to the other port.

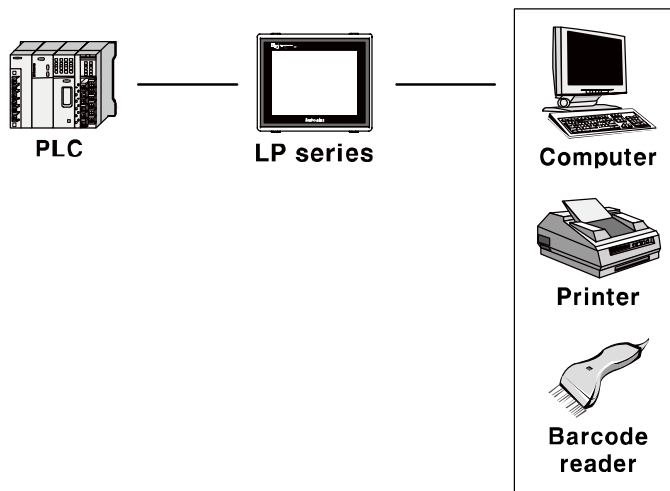

- Connection of CH1 and CH2  
Connect PLC to LP ports.  
It is able to connect even if CH and CH2 are not same type PLC, LP can relay data exchange between CH1 and CH2 according to configuration.

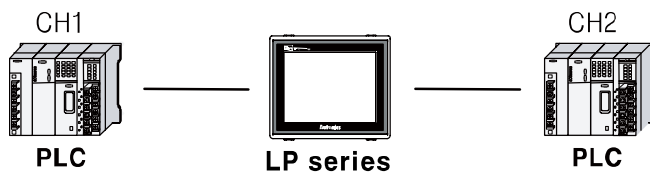

- Connection of plural PLCs

It is able to connect same device type to CH1 and CH2 as up to 32 by each.

In this case, LP can link data between CH1-1 to CH1-n and CH2-1 and CH2-n and it is able not to use CH1 or CH2.

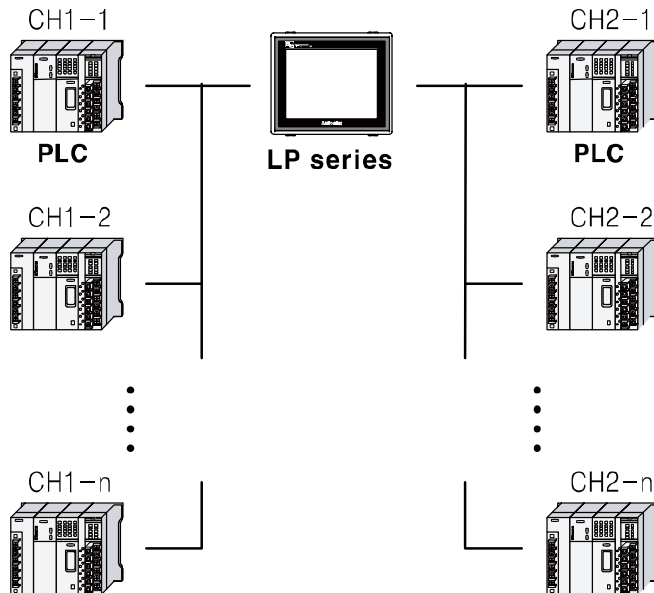

### 1.5.1 Communication interface

#### 1.5.1.1 Serial interface

##### (1) Serial port

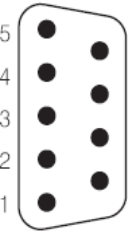
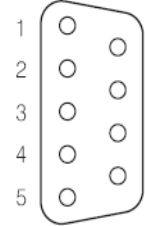
Port	Pin	Port	Pin		
<b>RS232C-A</b> <b>RS232C-B</b>  D-Sub 9Pin Male	1	Non-used	<b>RS422</b>  D-Sub 9Pin Female	1	TXD+
	2	RXD		2	RXD+
	3	TXD		3	Non-used
	4	DTR		4	Non-used
	5	SG		5	SG
	6	DSR		6	TXD-
	7	Non-used		7	RXD-
	8	Non-used		8	Non-used
	9	Non-used		9	Non-used

##### Serial port setting

Designate the desired settings for below items at [SET ENVIRONMENT] - [PLC SETTING].

Interface	RS232/RS422
Baudrate	300, 600, 1200, 2400, 4800, 9600, 19200, 38400, 57600, 115200bps
Data length	7, 8 Bit
Stop bit	1, 2 Bit
Parity	ODD, EVEN
Flow control	XON/XOFF, DSR/DTR, NONE

### 1.6 Part description

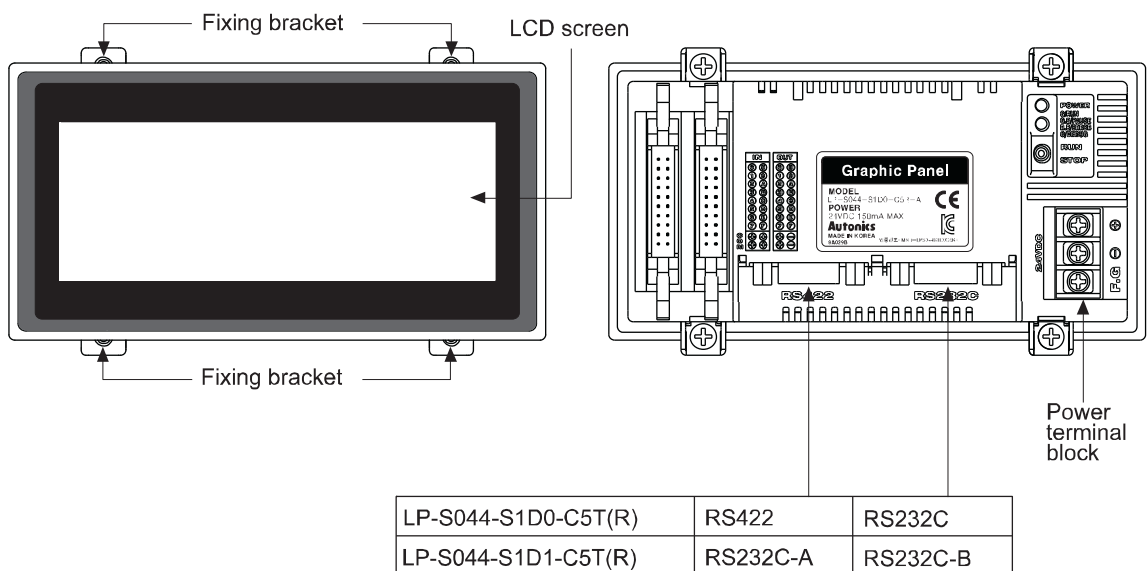

# 1.7 Dimensions

[Unit:mm]

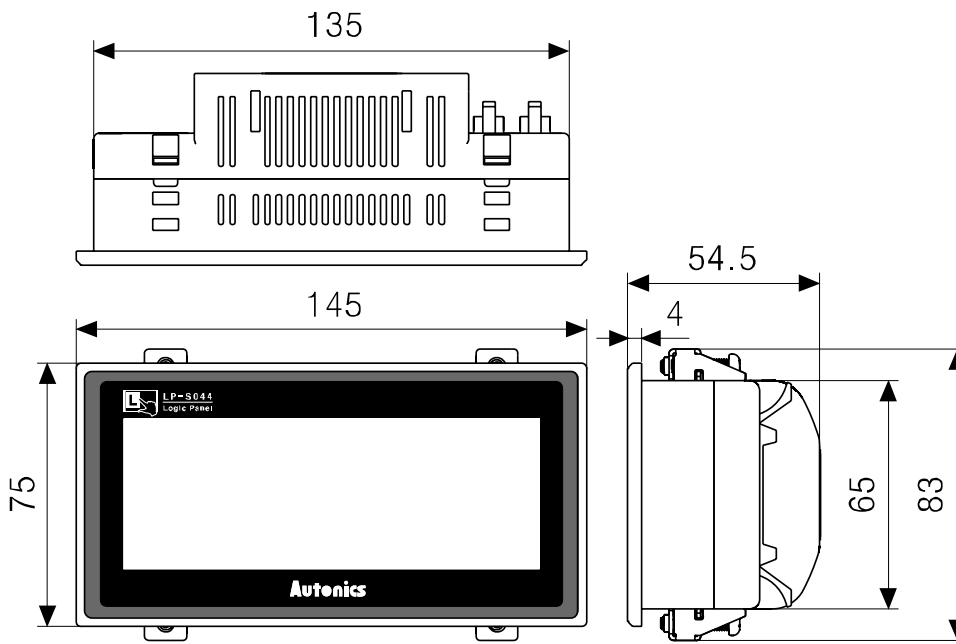

Fixing bracket

Panel cut-out

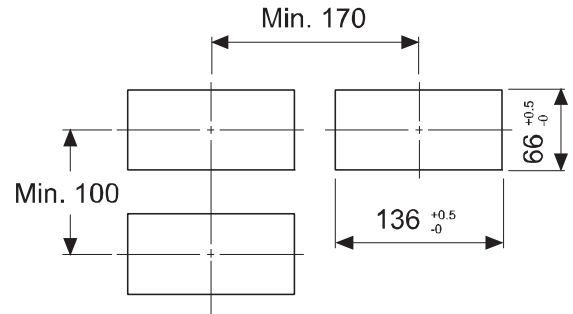
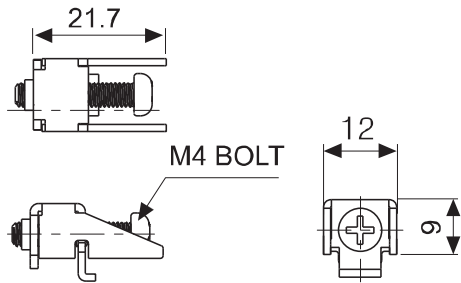

Panel thickness: max 4mm

## 2 Installation

### 2.1 LP installation

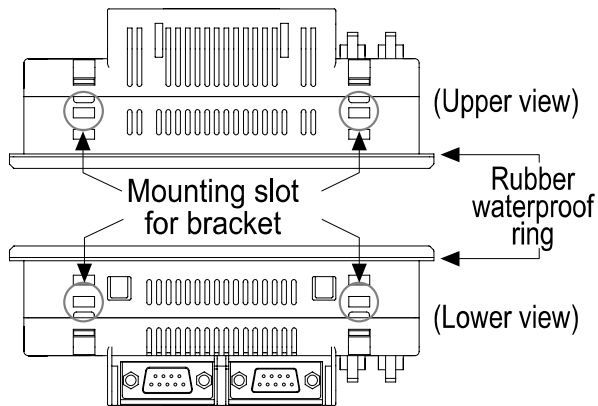

1st Set LP-S044 in panel.

2nd Set the fixing bracket to slot (upper 2, lower 2).

3rd Tighten the fixing bracket with 0.3N•m torque by M4 screw driver.

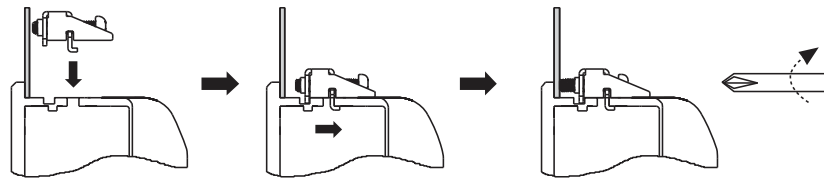

## 2.2 Power wiring

- For power supply, use the power line of which cross section is at least  $0.75\text{mm}^2$  and use the ground cable of which cross section is at least  $1.25\text{mm}^2$ .
- Use crimp-on type ring terminal with at least 3mm of internal diameter and less than 6mm of external diameter.
- Do not supply power before connecting power line.
- Check power polarity.
- Tighten the terminal screw with 0.5 to 0.8 N•m torque.
- Ground resistance should be less than  $100\Omega$  and ground it separately.

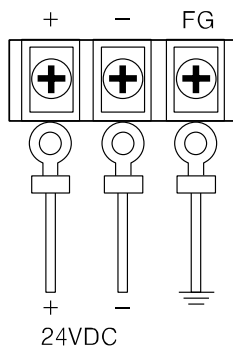

### Caution

Caution for power wiring

- Before connecting power line, you must check power polarity.
- Do not connect power when power is supplied.
- Observe following allowable voltage change range of power voltage.

Power voltage	24VDC
Allowable voltage change range	21.6V to 26.4VDC

- When connecting power, supply power by power supply which has inner protection circuit. If the power supply which does not have inner protection circuit is used, you must install protection circuits such as fuse before using this.
- As below figure, LP power must be separated with motor, other I/O devices power.

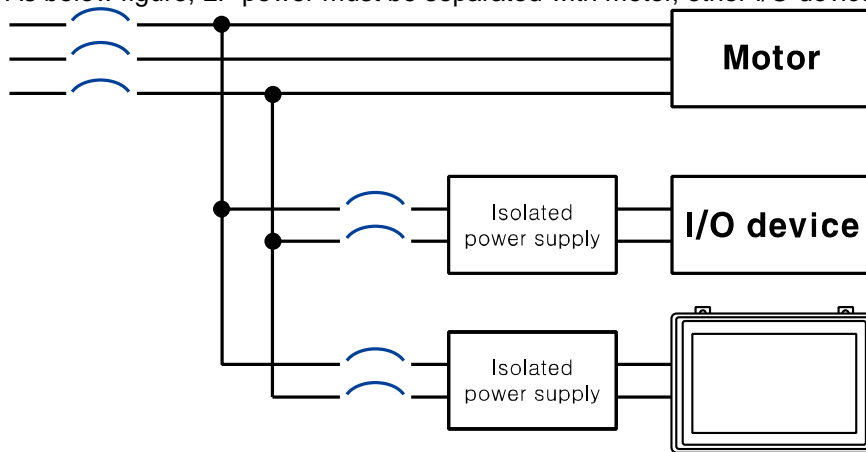

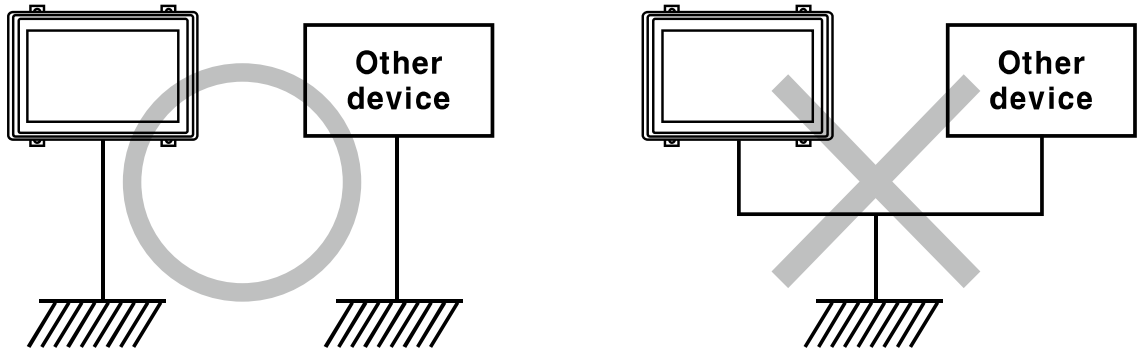

## 2.2.1 Ground wiring

**Caution**

Caution for ground wiring

- Connect max. 100Ω of ground resistance.
- Diameter of cable for ground wiring connection should be over than 2 mm<sup>2</sup>.
- As above figure, separate from other device's ground wire.

## 2.2.2 Input wiring

Consider required voltage for wiring I/O cable, and use optimal diameter cables.

### (1) Input terminal wiring

Inner input module of LP-S044 series is NPN open collector (source type) type.

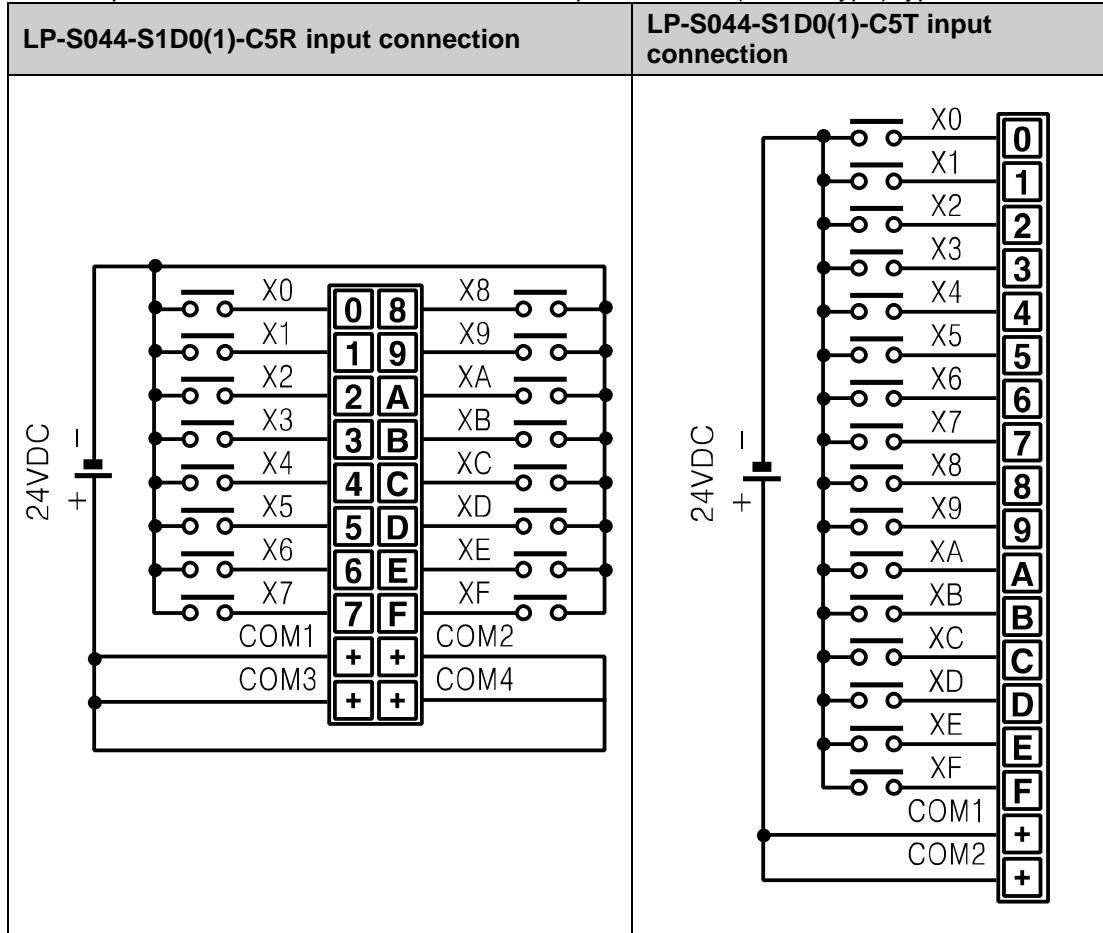

### Caution

- Divide I/O cable by color. Do not wire I/O cables to same duct.
- Keep min.100mm distance from power line and other high voltage line to wire.

(2) Connection method by input device type

- Connect with relay output type

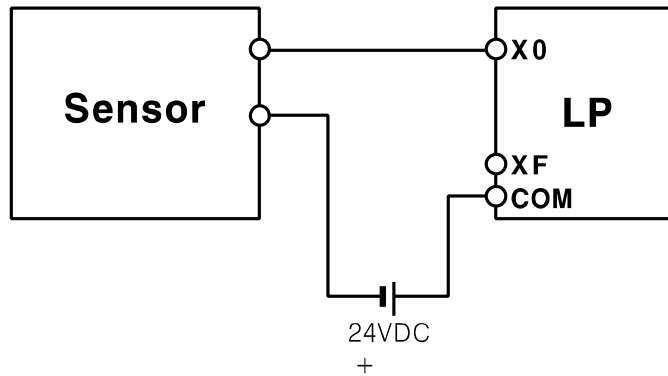

- Connect with NPN open collector output type

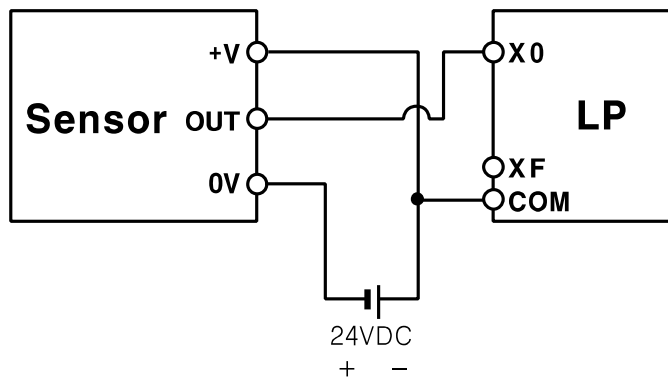

2.2.3 Output wiring

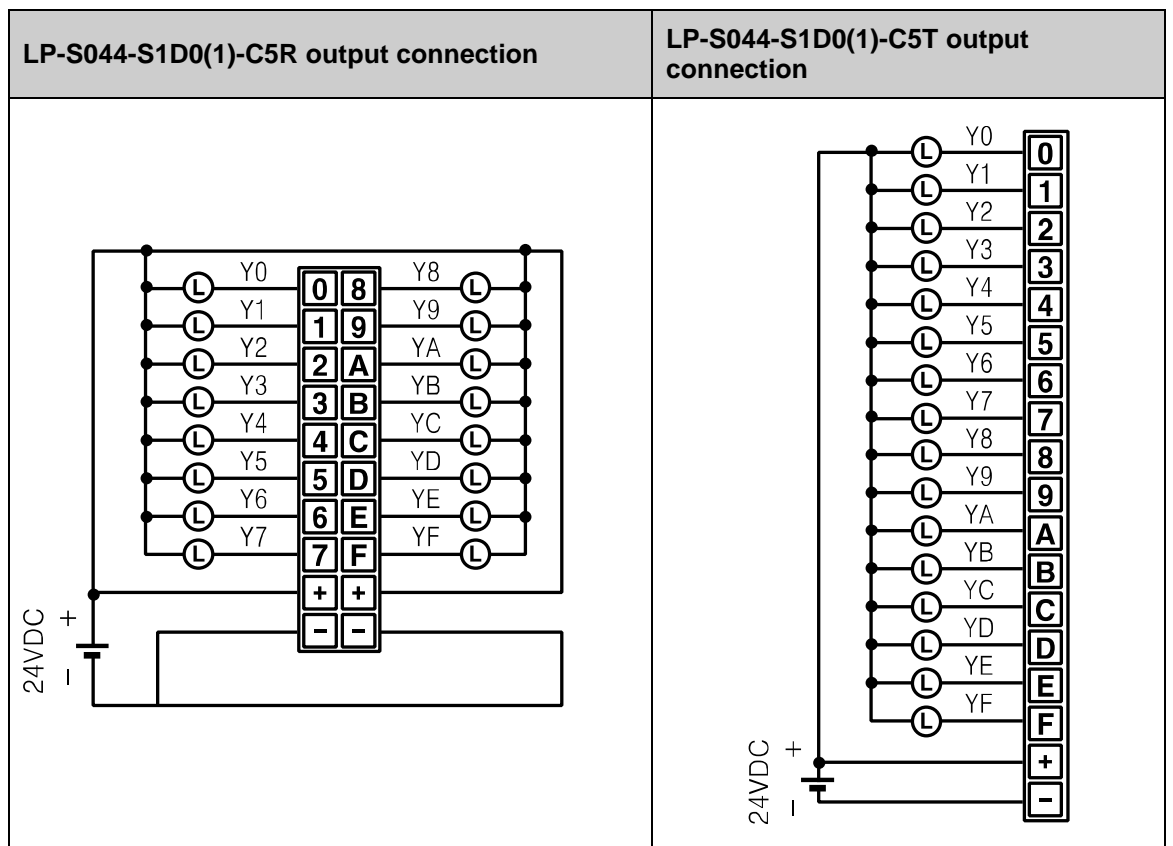

## 2.3 Battery replacement

Please contact our service center to replace LP battery.  
It may cause an explosion or a fire when using improper battery.

## 2.4 Caution for using

- Use communication cable after checking whether there is break or short.
- Please install power switch or circuit-breaker in order to cut power supply off.
- Separate this unit from high voltage line, power line to avoid inductive noise.
- Do not use this product at below places where causes serious malfunction.
  - ① Place where there is severe vibration or impact.
  - ② Place where dust exists, or corrosion causing environments.
  - ③ Place where strong field or electric noise are generated.
  - ④ Place where temperature or humidity is beyond the specification.
  - ⑤ Place where strong alkalis or vibration or impact.
  - ⑥ Place where there are direct ray of sun.
- Installation environment
  - ① It shall be used indoor.
  - ② Altitude Max. 2,000m
  - ③ Pollution Degree 2
  - ④ Installation Category II
- It may cause malfunction if above instructions are not followed.



### Caution

Do not install this product as below places.

- A place where ambient temperature is outside the range of 0°C to 50°C.
- A place where ambient humidity is outside the range of 35% to 85% RH.
- A place where sudden temperature change occurs frequently (so dew may form on the product).
- A place where the product is not likely to be protected from direct sunlight and rain.
- A place exposed to dust or metallic fragments.
- A place exposed to corrosive or flammable gas.
- A place where continuous impact and vibration may occur.
- A place directly exposed to noise sources from high voltage transformers, current transformers, main power cables, power systems and frequency converters.

Pay attention to the following when installed:

- Do not let conductive substances from panel cut-out or wiring ducts enter into LP.
- Make sure to allow enough space to handle the LP.

Secure enough space to maintain inside temperature and humidity of the panel when you mount LP.

## 3 Device Construction

### 3.1 Device element

- GP read device [UW, UB]  
This area is for controlling graphic panel function.  
For more details, refer to 'GP Editor user manual'.
- GP write device [UW, UB]  
This area is for displaying graphic panel state.  
For more details, refer to 'GP Editor user manual'.
- GP user device [UW, UB]  
This area is for using graphic panel function, general-purpose communication (universal communication) etc.  
  
Input device [X]  
It reads all input port status before executing program scan.  
  
This structure is for transmitting this to inner memory related X device area and utilizing this on the program.
- Output device [Y]  
After executing program scan, it transfers all inner memory values related Y device area by output port.
- Recipe device [R]  
It is a device used when using the recipe function of graphic panel.
- Virtual device [V]  
It is the used area for matched automatically device area by system when using user defined function. User cannot use this device area.  
For more details, refer to 'SmartStudio programming manual's '3.8 Usages of user defined functions'.
- Special device [F]  
This area is for displaying and controlling several information and status about PLC functions.  
For more details, refer to 'SmartStudio programming manual's 4. Special device'.
- Index device[Z]  
It is a device that utilizes allotted device as index by indirect designation method.  
The usage is as below.
- In case of  $Z0 = 100$ , D10Z0 is as D110.  
Therefore, if you use appropriate device address and index device [Z] as mixed, it is able to change appropriate device address to user defined address by indirect designation method.



Ex.

[Allots decimal 100 to Mov 100 Z0: Z0 device.]

Mov D10Z0 D101: D10Z0

Therefore, the current value of D110 device is changed with the current value of D101 device.

- Timer(coil)[T], Timer(current value)[T], Timer(set value)[TS]  
When current value of timer is arrived at set value, it operates coil(timer).  
It supports 100ms, 10ms timer.  
For more details, refer to related timer instructions from 'SmartStudio user manual'.
- Counter(coil)[C], Counter(current value)[C], Counter(set value)[CS]  
When current value of counter is arrived at set value, it operates coil.  
For more details, refer to related counter instructions from 'SmartStudio user manual'.
- Inner auxiliary device [M]  
This area is allotted only for inner operation which cannot control external I/O, for example, it receives external input and cannot execute external load.
- Step device[S]  
This allotted area is for controlling step such as the progress which needs the order.
- Link device[L]  
It is a device for linking external device, and data.  
If this is not used as data link, it is available as data device or inner device.
- Data device[D]  
It is an allotted device for saving numeral, ASCII, etc's data.
- Pointer[\*]  
Pointer[\*] makes device use with special method.  
You can use pointer (\*) to every word device as following example.  
The device with pointer (\*) displays same type device as the value type of the device.



**Ex.**

In case of M100 = 123, M123 = 999, \*M100 displays M123 which is M device related with M100 value as 123.

As following mnemonic, M0 has 999 value.

```
MOV M123 999
```

```
MOV *M100 M0
```

## 3.2 Device range

### 3.2.1 Bit device range

Mark	Name	Range	UB correspond address	Size
UB	READ AREA	UB000000 to UB00014F	UB000000 to UB00014F	00015F bit
UB	WRITE AREA	UB000015 to UB00029F	UB000015 to UB00029F	00015F bit
UB	USER AREA	UB000030 to UB01999F	UB000030 to UB01999F	01969F bit
R	File device	R0 to R3999F	UB020000 to UB05999F	04000F bit
V	Virtual device	V0 to V255F	UB061000 to UB06355F	00256F bit
F	Special device	F0 to F255F	UB064000 to UB06655F	00256F bit
Z	Index device	Z0 to Z255F	UB067000 to UB06955F	00256F bit
X	Input device	X0 to X255F	UB044000 to UB07255F	00256F bit
Y	Output device	Y0 to Y255F	UB080000 to UB08255F	00256F bit
T	Timer contact	T0 to T255	UB100000 to UB10015F	00256 Bit
C	Counter contact	C0 to C255	UB150000 to UB15015F	00256 Bit
M	Auxiliary device	M0 to M9999F	UB200000 to UB29999F	10000F bit
S	Step device	S0.00 to S255.99	UB360000 to UB36255F	00256F bit
L	Link device	L0 to L255F	UB380000 to UB38999F	01000F bit

### 3.2.2 Word device range

Mark	Name	Range	UB correspond address	Size
UW	READ AREA	UW00000 to UW00014	UW00000 to UW00014	00015 Word
UW	WRITE AREA	UW00015 to UW00029	UW00015 to UW00029	00015 Word
UW	USER AREA	UW00030 to UW01999	UW00030 to UW01999	01969 Word
R	File device	R0 to R3999F	UW02000 to UW05999	04000 Word
F	Special device	F0 to F255	UW06400 to UW06655	00256 Word
X	Input device	X0 to X255	UW04400 to UW07255	00256 Word
Y	Output device	Y0 to Y255	UW08000 to UW08255	00256 Word
T	Timer present value	T0 to T255	UW11000 to UW11255	00256 Word
C	Counter present value	C0 to C255	UW16000 to UW16255	00256 Word
M	Auxiliary device	M0 to M9999	UW20000 to UW29999	10000 Word
L	Link device	L0 to L255	UW38000 to UW38999	01000 Word
D	Data device	D0 to D9999	UW40000 to UW49999	10000 Word
V	Virtual device	V0 to V255	UW06100 to UW06355	00256 Word

### 3.3 Application of UW, UB corresponding

LP series is integrated with PLC and HMI device as one. You can monitor and control the device of the additionally connected devices (PLC, etc).

General PLCs usually have same device name regardless manufacture and model type.

To monitor and control the device of the connected external device with LP series, it is needed to divide devices between PLC's and LP's.

To divide devices between PLC's and LP's during drawing the data in GP Editor, LP device should be as UW, UB device as following '12.3 UW correspondence table'

Additionally connected controllers is drawn with their characteristics device name.



## 4 System Organization

### 4.1 Stand-alone

As following organization, stand-alone system with LP-S044 monitors the program for controlling several type I/O and operation items (device, parameter) without additional device. You can also organize controlling organization for specific operation items with touching.

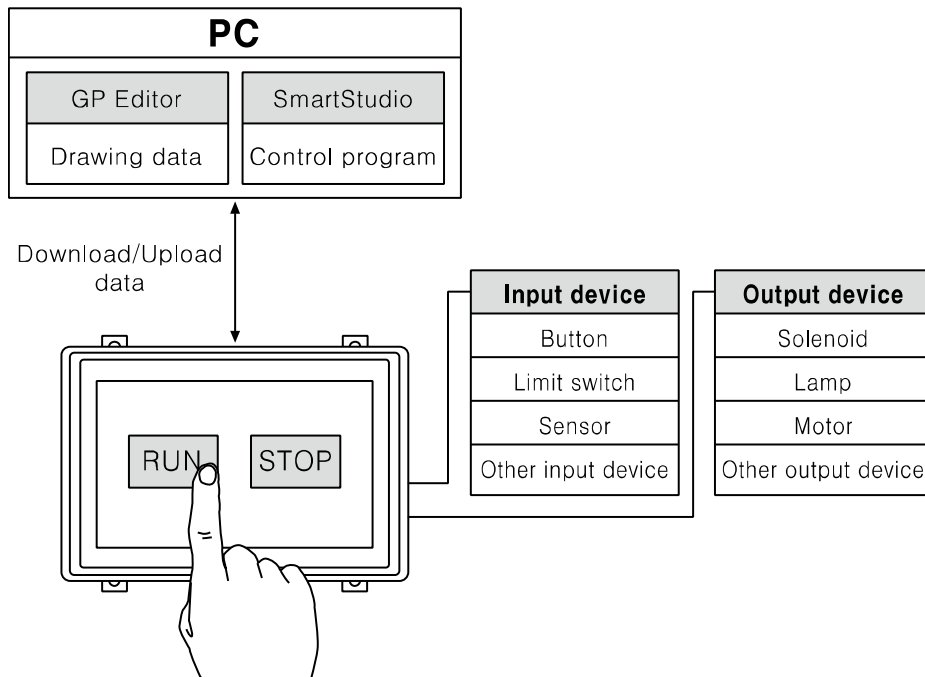

## 4.2 Connection with controller

### 4.2.1 1:1 organization

You can organize the system to monitor the action element (device, parameter, etc) status of the connected specified device during executing LP-S044 operation.

For monitoring inner device of LP-S044 and inner device of the connected controller at the same time, refer to '12.3 UW correspondence table'.

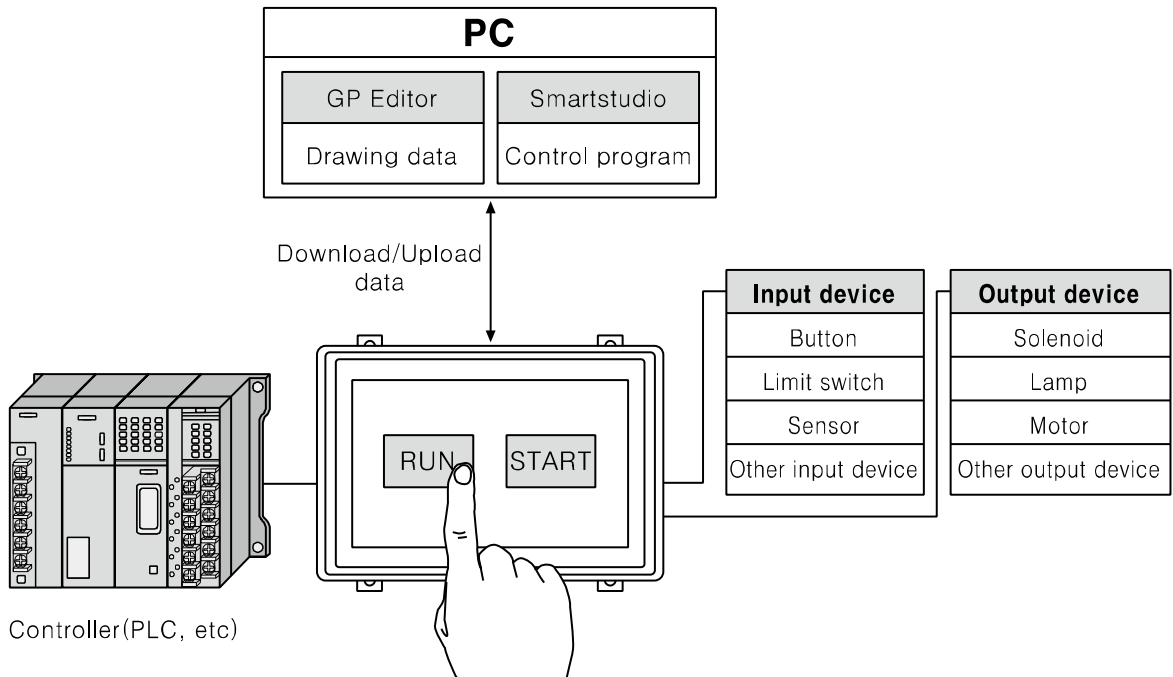

#### Note

If there are too much draw data, screen processing speed may be reduced. However, control program speed is not affected.

To monitor external connected devices, be sure that draw data properly not to cause problems for communication processing speed.

### 4.2.2 1:N organization

You can organize the system to monitor the action element (device, parameter, etc) status of the connected specified N devices which are same type controllers (PLC etc) during executing LP-S044 operation as following figure.

For monitoring inner device of LP-S044 and inner device of a connected controller at the same time, refer to '12.3 UW correspondence table'.

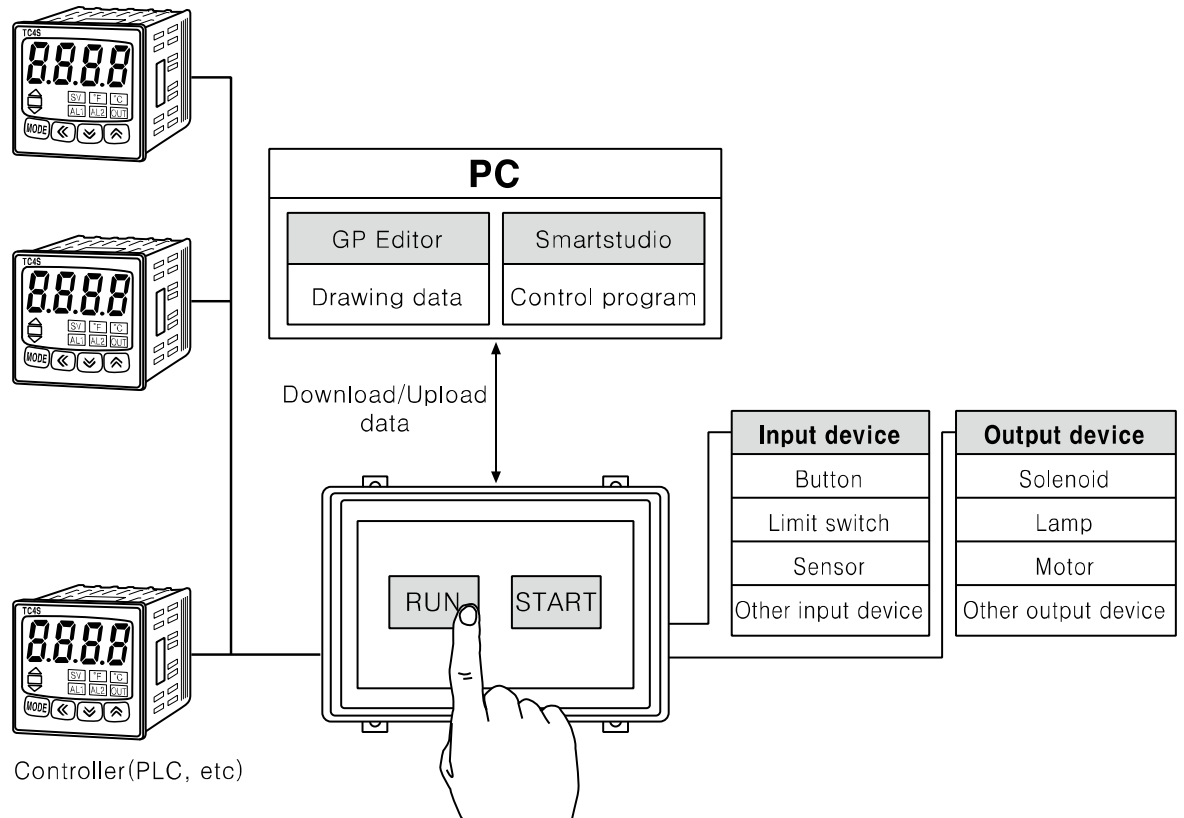

You can connect devices up to 32, it may be different by the product.

Respond time is different by the connected devcie during communication, data renewal time may be longer.

For more details, refer to 'GP, LP user manual for communication'.

### 4.2.3 Heterogeneous organization

You can organize the system to monitor the action element (device, parameter, etc) status of between two devices which are connected at each port as different type controller (PLC, etc) during executing LP-S044 operation as following figure.

For monitoring inner device of LP-S044 and inner device of a connected controller at the same time, refer to '12.3 UW correspondence table'.

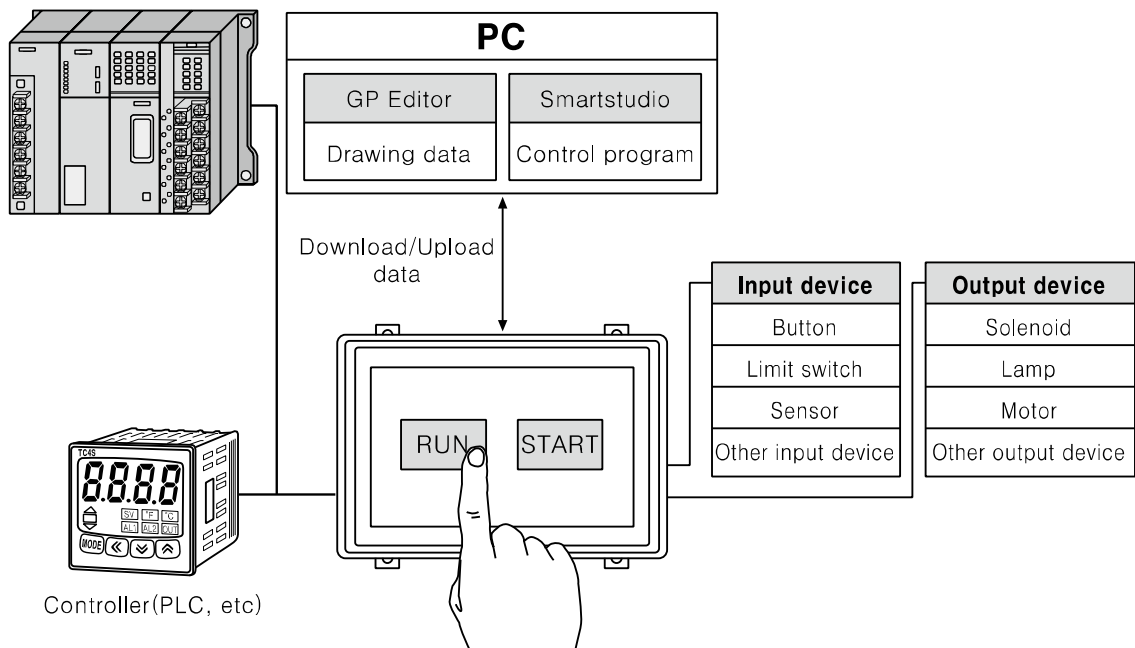

For more details, refer to 'GP, LP user manual for communication'.

### 4.3 Universal organization

As following figure, you can organize the system to monitor or control host unit data by universal communication during executing LP-S044 operation.

For monitoring inner device of LP and inner device of an additionally connected controller at the same time, refer to '12.3 UW correspondence table'.

For more details, refer to '5.4 Universal protocol' of 'GP,LP user manual for communication'.

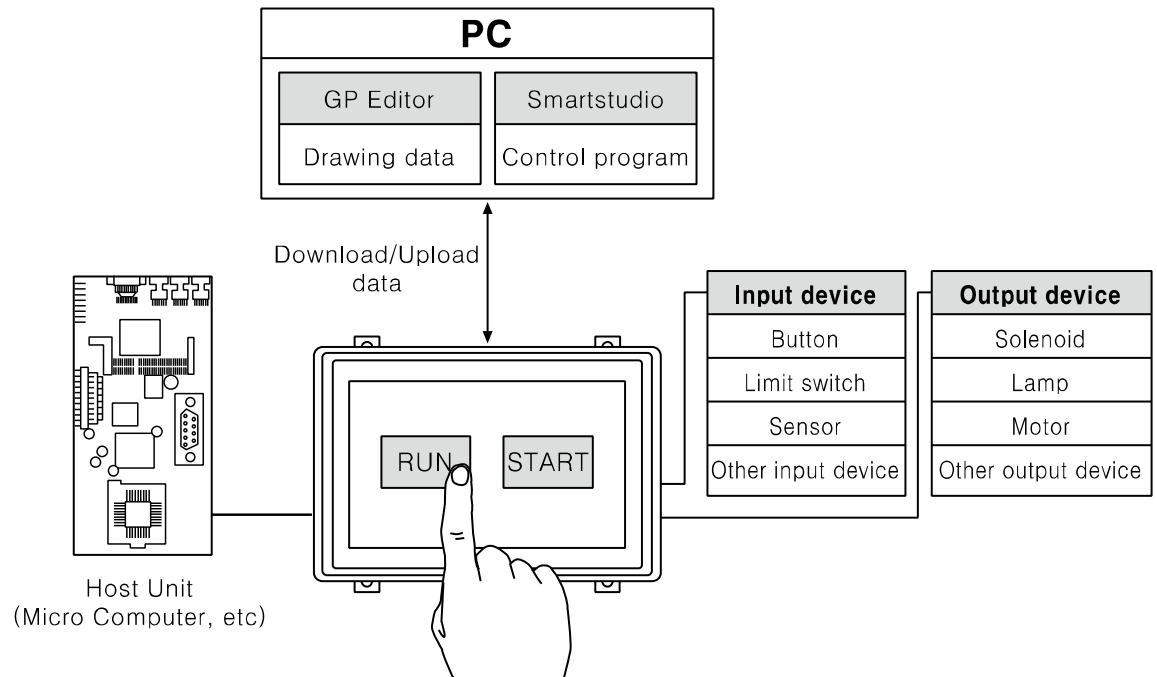

## 4.4 Connect with barcode, printer

As following figure, you can organize the system to read barcode data by connecting barcode reader, or to print alarm history by connecting serial print during executing LP-S044 operation.

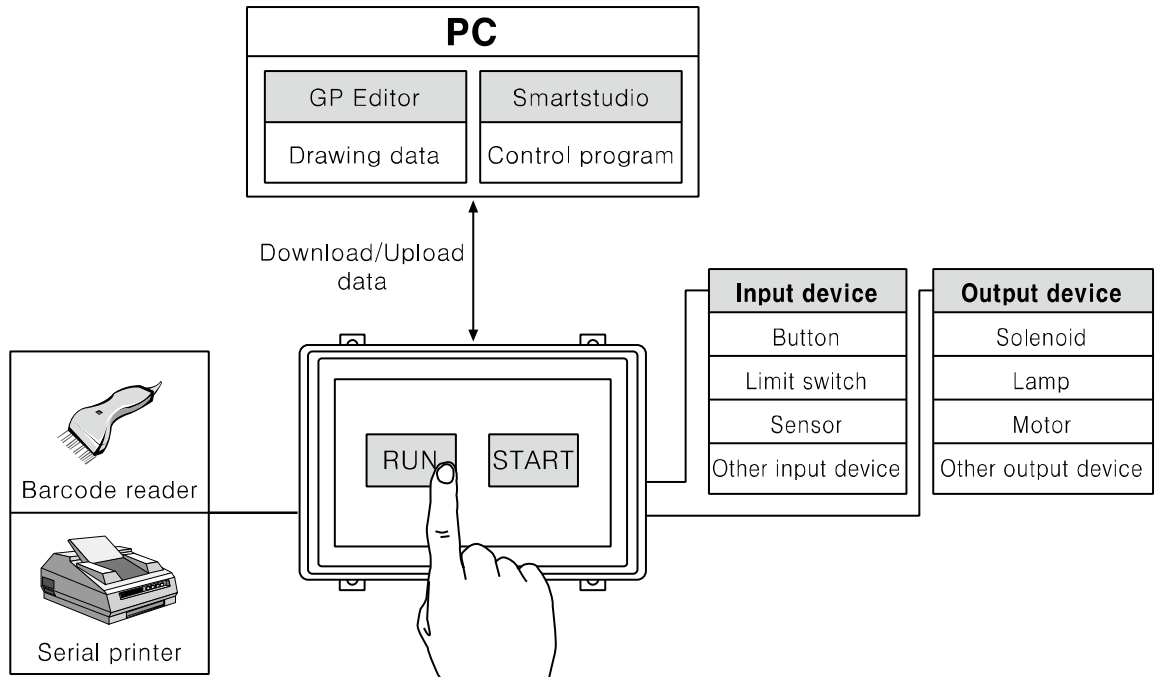

For more details, refer to 'GP, LP user manual for communication'.

## 4.5 Operation mode

Operation mode defines operation status, program execution of LP-S044.

You can change mode by switch of LP, or remote control in SmartStudio. Be sure that when mode is change, inner device and special device status are changed.

LP-S044 has four kinds of operation mode; RUN, STOP, PAUSE, and DEBUG mode.

- **RUN mode**  
It saves external contact status to inner memory and executes the operations such as step order, branch instruction, or interrupt until END line. After this, it outputs repeatedly output device memory value as external output signal.
- **STOP mode**  
It stops user defined program execution.  
At the same time, it initializes inner memory data (except latch area, parts of special device) and makes every external output signal turn OFF to turn OFF external output signals by program.
- **PAUSE mode**  
It stops only user defined program execution.  
It maintains inner memory and external output signal.
- **DEBUG mode**  
It is waiting status for executing debug instruction by stopping user defined program at 0 step. At the same time, it initializes inner memory data (except latch area, parts of special device) and makes every external output signal turn OFF.

### 4.5.1 Change operation mode

#### (1) Change inner device status when entering operation mode

MODE	RUN	STOP	PAUSE	DEBUG
Inner device(Latch area)	Maintain	Maintain	Maintain	Maintain
Inner device(Non latch area)	Delete	Delete	Maintain	Delete

#### (2) Change main special device status when entering operation mode

MODE	Special device
RUN	Deletes special device for error
STOP	Maintains special device for error, maintains special device operation for system clock
PAUSE	Maintains special device operation for system clock
DEBUG	Deletes special device for error

※1. For other special device operation, refer to 'SmartStudio programming manual's 4. Special device'.

#### (3) LP mode switch

LP mode switch is for changing mode RUN mode or STOP mode.

LP mode	Description
RUN	Enable to mode change from SmartStudio. Executes REMOTE function and when changing STOP → RUN, it executes mode changing function to RUN mode.
STOP	Disable to mode change from SmartStudio. Executes STOP function.

## 4.6 Program processing procedure

When power ON or LP mode switch is RUN, as following processing, it processes operation.

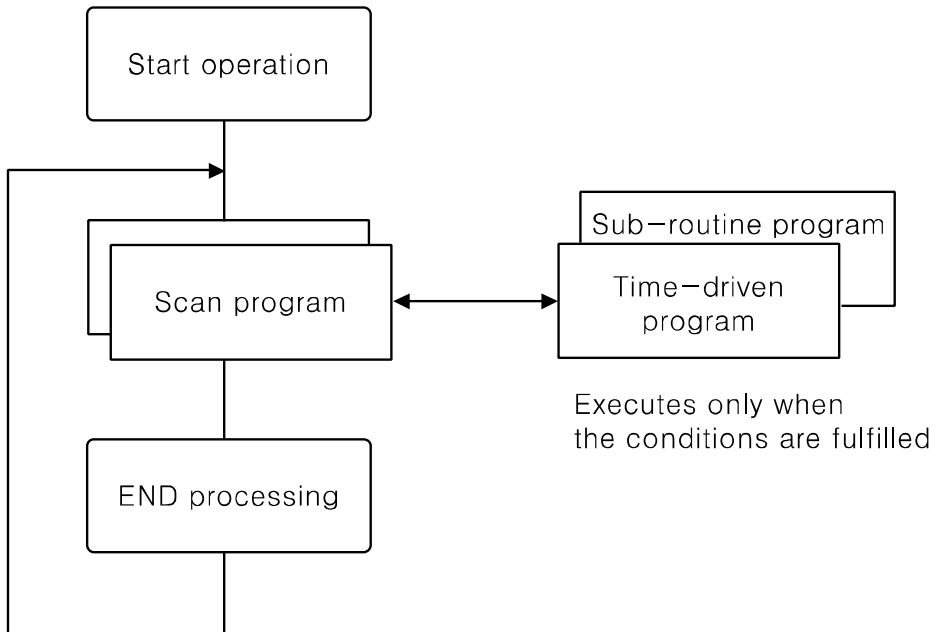



## 4.7 Connect with GP Editor

Communication between PC and LP-S044 is available with serial communication. Setting method is as below.

1st Enter system setting menu.

Touch left-upper point as default position of system setting menu.

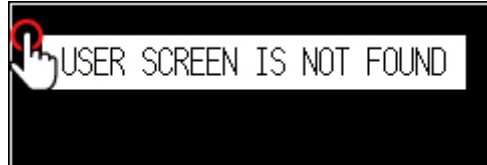

2nd Select [SET ENVIRONMENT]- [PLC SETTING]..

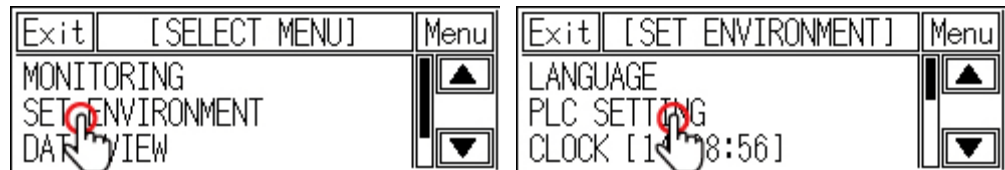

3rd Check that CH2 configuraiton is as 'EDITOR', and connected connection port with LP-S044 is as 'RS232C'.

If the configuration is not as 'EDITOR', touch (PROTOCOL) part and cofigure as 'EDITOR'.

Touch this, it rotates in order as EDITOR → PRINTER → BARCODE → MONITOR.

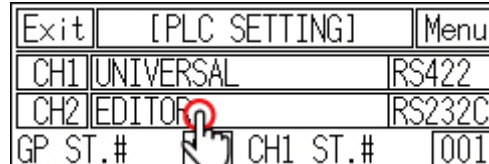

Touch (PORT) area to configure the connection port of LP-S044.

Touch this, it rotates in order as [RS422] and [RS232C].

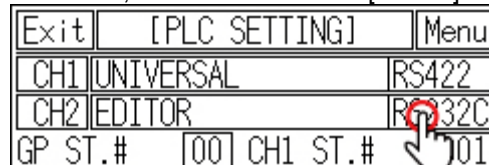

To check baud rate, data bit, stop bit, parity, etc, touch the desired channel 'CH1' or 'CH2'. It is able to download and upload GP Editor content to LP-S044 only when the baud rate between GP Editor and LP-S044 are configured as same.



4th Touch [Menu], current setting values are saved and it returns to previous menu.

Touch [Exit], current setting values are saved and it returns to user screen after exiting system setting menu.

### 4.7.1 GP Editor configuration

1st Select [Common]-[GP/PLC Type] of GP Editor menu.

Designate GP/LP type as the model name LP-S044 by pull-down menu.

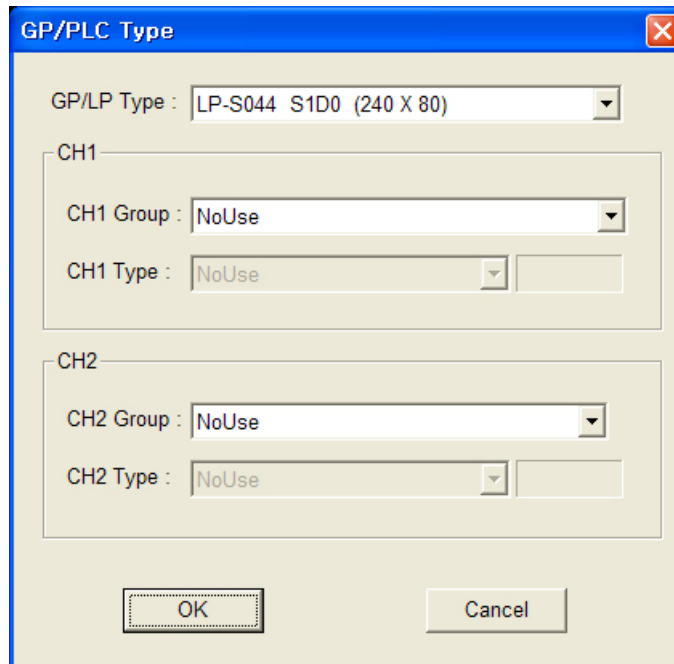

2nd Select [Communication]-[Option] and 'Option' dialog box appears.

Designate communication configuration as same as that of from LP-S044. (LP-S044 supports only serial communication, therefore Ethernet and USB communication are not activated.) For more details of each option, refer to 'GP Editor user manual'.

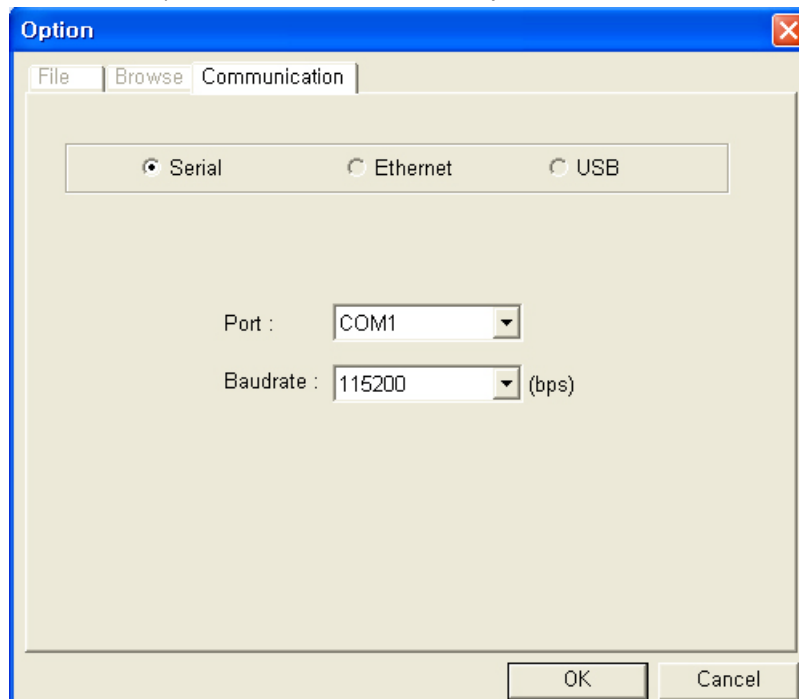

3rd After configuration, connect LP and PC by communication cable to download and upload drawn program from GP Editor.

## 4.8 Connect with SmartStudio

### 4.8.1 LP configuration

Please refer to '4.7 Connect with GP Editor' to configure LP.

### 4.8.2 SmartStudio configuration

Communication between PC and LP-S044 is available with serial communication. Select [Online]-[Communication Option] in SmartStudio menu to configure communication between LP-S044 and PC. For configuration method by each item, refer to 'SmartStudio user manual'.



## 5 Start up LP

This chapter describes start up procedure from supplying power to LP-S044 to switching user screen.

### 5.1 Checking list before supplying power

Before supplying power to LP-S044, please check the following list.

No	Check	Description
1	Install status	Check waterproof rubber ring is installed.
		Check all 4 fixing brackets are installed.
		Check fixing brackets are fixed with approved tightening torque.
2	Emergency stop circuit	Check individual emergency stop circuit at the external LP-S044 is placed.
		Check there is problem to emergency stop when error occurs.
3	Ground	Check ground cable is installed with separated other device ground cable.
		Check there is 3rd grounding.
4	Power cable	Check cable connection by polarity.
		Check the tightening status of screws on terminal.
5	I/O wiring	Check I/O wiring status.
		Check connector connection status.
6	Power	Check power voltage.
		Check this is installed as separated other device power.

## 5.2 Operation order

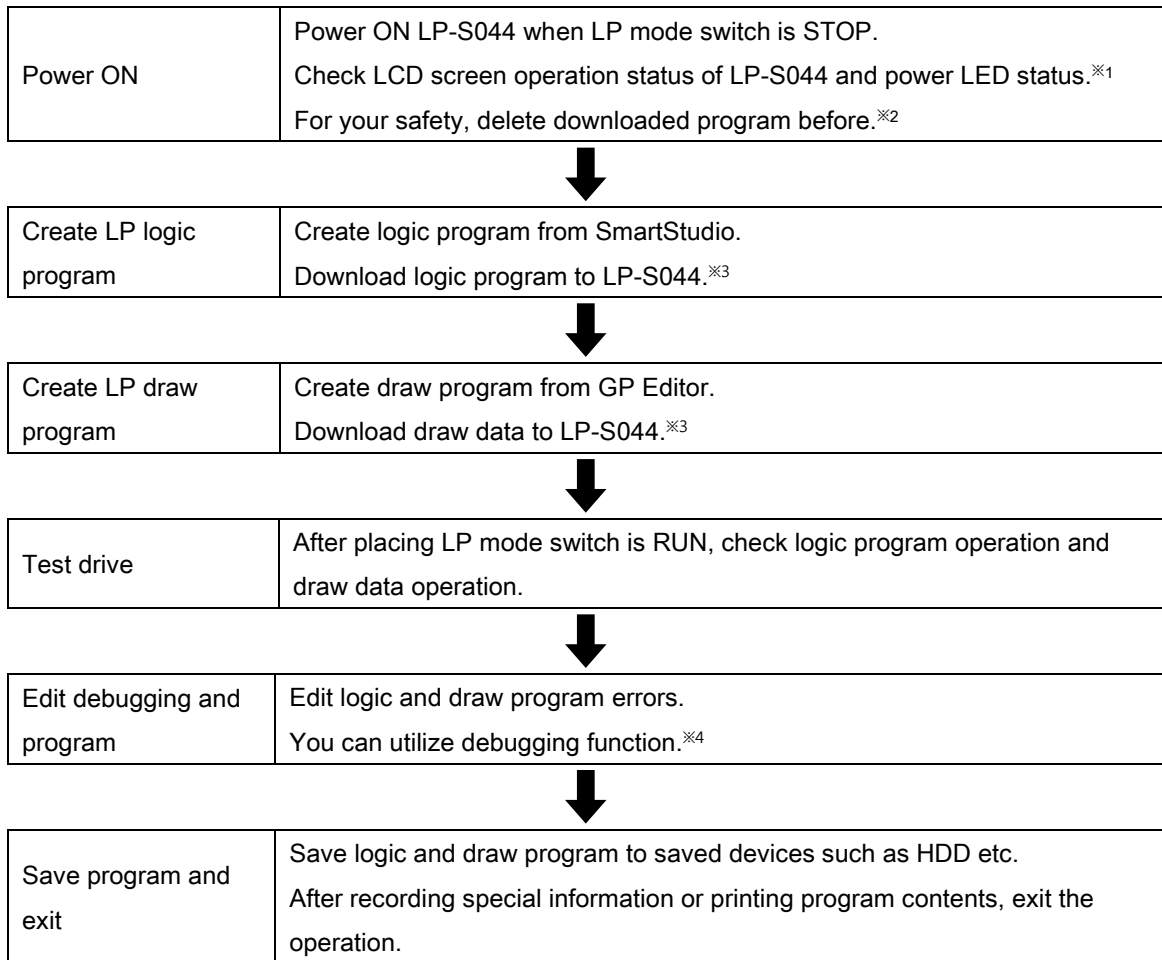

※1. If there are error for LCD screen operation of LP-S044 and power LED, refer to '9 Troubleshooting'

※2. To delete program, [SET ENVIRONMENT]-[CLEAR USER DATA] of system setting menu or refer to 'SmartStudio user manual'.

※3. Connection with SmartStudio, GP Editor and LP-S044 is able to connect(download, upload, monitoring) by designated EDITOR port from [SET ENVIRONMENT]-[PLC SETTING] of system setting menu. Therefore, you cannot connect SmartStudio and GP Editor at the same time.

For example, during monitoring logic program of LP-S044 in SmartStudio, you cannot download draw data of GP Editor to LP-S044. For downloading draw data, you should disconnect SmartStudio and connect GP Editor.

※4. SmartStudio supports several functions for debugging. For more details, refer to 'SmartStudio user manual's 7 Debug'.

## 6 System Screen

### 6.1 Organization of system screen

System setting screen appears for monitoring, set environment, data view, set function and set parameter by touching system screen calling. Select each menu and their sub-menu appears.

The system screen organization is as below.

LP-S044 system setting menu	MONITORING	DEVICE MONITOR
		I/O MONITORING
	SET ENVIRONMENT	LANGUAGE
		PLC SETTING
		CLOCK
		CLEAR USER DATA
		MENU CALL KEY
		BUZZER
		OPENING
		BACKLIGHT
		BATTERY
		CONTRAST
	DATA VIEW	BASE SCREEN
		WINDOW SCREEN
		COMMENT
		MEMORY SIZE
		MODEL & VERSION
	SET FUNCTION	DATA TRANSFER
		TIME SWITCH
		PRINT OUT
	SET PARAMETER	FILTER
		INTERRUPT
		4 X 4 KEYPAD
7 SEGMENT DISPLAY		
SYNCHRONOUS SERIAL		

## 6.2 Operation of system screen



No.	Function and operation
①	Moves from system screen to user screen.
②	Displays current screen's menu.
③	Moves to upper parameter.
④	Moves to up and down items.
⑤	Touch the desired menu and it moves to that menu.



### 6.3 Monitoring

#### 6.3.1 Device monitor

Device monitor menu is for monitoring inner device of connected device or for designating the value to inner device of LP.

It is able to monitor bit or word device of connected device, special function device, inner bit device of LP, or inner word device area.

Monitorable device is different depending on connected device. Confirm monitorable device by each device from 'GP, LP user manual for communication'.

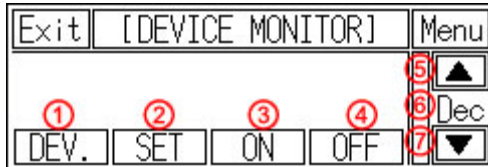

No.	Function and operation
①	Calls input window to select special device set as CH1
②	Calls input window for word device value at cursor.
③	Sets bit device value at cursor.
④	Resets selected bit device.
⑤	Displays close up device list.
⑥	Touch this, Dec or Hex is displayed in order. Dec means decimal, Hex means hexadecimal.
⑦	Displays close down device list.

#### 6.3.2 I/O monitoring

It monitors I/O state of LP-S044.



No.	Function and operation
①	Monitors input contact X0 to XF state.
②	Monitors output contact Y0 to YF state.

## 6.4 Set Environment

SET ENVIRONMENT menu is for checking or re-setting the set status for general operation of LP.

According to each set status, it may affect to LP operation directly/indirectly. As screensaver function, password set and remove is also available depending on user's decision.

### 6.4.1 Language

User language for LP displays user language for displaying user-defined screen, international character font, English font, vector font. You can designate system language for LP inner system language.

- Supported language: It supports Korean, English, Japanese, Chinese, Russian and the other languages are supported later with upgrade.
- Font type: It supports various fonts by each language.

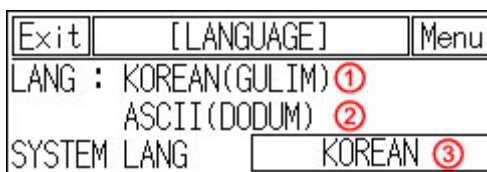

No.	Function and operation
①	Displays designated user language and font. ※1
②	Displays designated ASCII character font. ※1
③	Touch the desired system language as displayed

To change system language, download new fonts from GP Editor.



#### Note

It prevent error at designing level with using the same font between designing font from GP Editor and used font in LP-S044.

## 6.4.2 PLC setting

This menu displays connected device to RS232C, RS422 port of LP-S044. You can designate station and connected port by each channel.

Exit	[PLC SETTING]	Menu
① CH1	MK-200S(CPU)	② ③ RS422
④ CH2	EDITOR	⑤ ⑥ RS232C
GP ST.#	⑦ 00	CH1 ST.# ⑧ 001

No.	Function and operation
① CH1 configuration line	Displays connected device and connect port for CH1. Touch this to select one from downloaded protocol in EDITOR, PRINTER, BARCODE and designate connect port. (Select RS232C or RS422 or depending on CH2 setting, CH1 may be changed as the other). Depending on the setting, CH1 may be changed as 'No Use'.
② CH1 PLC protocol	Displays PLC protocol of CH1
③ CH1 connect port	Displays connect port of CH1
④ CH2 configuration line	Displays connected device and connect port for CH2. Touch this to select one from downloaded protocol in EDITOR, PRINTER, BARCODE, MONITOR protocol and designate connect port. (Select one of RS232C or RS422 or depending on CH1 setting, CH2 may be changed as the other.) If CH1 is SLAVE, MONITOR does not appear.
⑤ CH2 PLC protocol	Displays PLC protocol of CH2
⑥ CH2 connect port	Displays connect port of CH2
⑦ LP station configuration touch key	Touch this and input key pad for decimal (DEC) appears. It is available the range from 0 to 31.
⑧ Configuration touch key by each channel	Touch this and input key pad for decimal (DEC) appears. It is available the range from 0 to 255.

## (1) In case of using only CH1 configured in GP Editor

Exit	[PLC SETTING]	Menu	Exit	MK-200S(CPU)	Menu
① CH1	MK-200S(CPU)	③ ⑤ RS422	B/R	38400bps	
② CH2	EDITOR	④ ⑥ RS232C	DATA	8BIT	STOP 1BIT
GP ST.#	[00]	CH1 ST.#	PARITY	NONE	F/C XON/XOFF

Item	Operation with touching
①, ② Communication configuration by channel	Moves communication configuration setting window for selected connected device. You can designate baudrate, data bit, parity, stop bit, and flow control for each channel.
③ Displays CH1 protocol	Rotates in order as downloaded protocol → EDITOR → PRINTER → BARCODE → UNIVERSAL → DEFAULT protocol
④ Displays CH2 protocol (as EDITOR for default)	Rotates in order as EDITOR → PRINTER → BARCODE → MONITOR (If CH1 is SLAVE, MONITOR does not appear.)
⑤ Displays CH1 connect port (Designates automatically as non-using port in ④)	LP-S044-S1D0: RS422 A PORT ↔ RS 232C B PORT
	LP-S044-S1D1: RS232C A PORT ↔ RS232C B PORT
⑥ Displays CH2 connect port (Designates automatically as non-using port in ②)	LP-S044-S1D0: RS422 A PORT ↔ RS 232C B PORT
	LP-S044-S1D1: RS232C A PORT ↔ RS232C B PORT

(2) In case of using only CH2 configured in GP Editor

Exit	[PLC SETTING]	Menu	Exit	FX1N_Tool	Menu
① CH1	No Use	③ ⑤ RS422	B/R	38400bps	
② CH2	FX1N_Tool	④ ⑥ RS232C	DATA	8BIT	STOP 1BIT
GP ST.#	00	CH1 ST.#	001	PARITY	EVEN F/C XON/XOFF

Item	Operation with touching
①, ② Communication configuration by each channel	Moves communication configuration setting window for selected connected device. You can designate baudrate, data bit, parity, stop bit, and flow control for each channel. If CH1 is as NoUse, it is not able to communication configuration.
③ Displays CH1 protocol	Rotates in order NoUse → EDITOR → PRINTER → BARCODE → UNIVERSAL → DEFAULT protocol
④ Displays CH2 protocol. (as downloaded protocol for default)	Rotates in order as downloaded protocol → EDITOR → PRINTER → BARCODE
⑤ Displays CH1 connect port (Designates automatically as non-using port in ④)	LP-S044-S1D0: RS422 PORT ↔ RS232C PORT
	LP-S044-S1D1: RS232C A PORT ↔ RS232C B PORT
⑥ Displays CH2 connect port (Designates automatically as non-using port in ②)	LP-S044-S1D0: RS422 PORT ↔ RS232C PORT
	LP-S044-S1D1 RS232C A PORT ↔ RS232C B PORT

## (3) CH1/CH2 details configuration

Exit	[PLC SETTING]	Menu
① CH1	MK-200S(CPU) ②	RS422
① CH2	FX1N_Tool ②	RS232C
GP ST.#	[00]	CH1 ST.# [001]

Exit	MK-200S(CPU)	Menu
B/R ③	38400bps	
DATA ④	8BIT	STOP 1BIT
PARITY ⑤	NONE	F/C XON/XOFF

  

Exit	FX1N_Tool	Menu
B/R	38400bps	
DATA	8BIT	STOP ⑥ 1BIT
PARITY	EVEN	F/C ⑦ XON/XOFF

No.	Function and operation
①	Touch this, detailed configuration screen for designated operation mode appears.
②	<p>Designate operation mode.</p> <ul style="list-style-type: none"> <li>CH1,2 protocol: Communication mode for set PLC by LP and GP Editor by each port.</li> <li>EDITOR: I/O mode for downloading user-designed data from GP Editor</li> <li>PRINTER: Print mode for printing alarm history of LP (For more details, refer to 'GP LP user manual for communication')</li> <li>BARCODE: Input mode for reading data from barcode. (For more details, refer to 'GP LP user manual for communication')</li> <li>MONITOR: Available only in CH2. Monitoring mode for PLC which is connected to LP from PC directly. LP is as transmitter by transmitting data from PC to PLC and data from PLC to PC. In case of MITSUBISHI FX-Series, editor mode is available for monitoring.</li> <li>NoUse: Displayed only not using appropriate CH.</li> </ul>
③	<p>Designate baud rate.</p> <p>Supports 300, 600, 1200, 2400, 4800, 9600, 19200, 38400, 57600, 115200 bps</p>
④	<p>Data: Designate data bit</p> <p>Supports 7 bit, 8 bit.</p>
⑤	<p>Parity: Designate parity type.</p> <p>Supports even, odd, or none parity.</p>
⑥	<p>Stop bit: Designate stop bit.</p> <p>Supports 1 bit, or 2 bit.</p>
⑦	<p>Flow control: Designate data flow control.</p> <p>Supports XON/ XOFF, or DSR/DTR.</p>

### 6.4.3 Clock

This menu is for setting or checking current time.

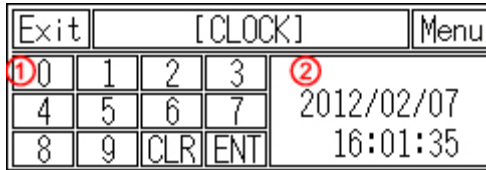

No.	Function and operation
①	Designate user designate time and data from current time. <ul style="list-style-type: none"> <li>• 0 to 9: Input set time.</li> <li>• CLR: Cancel set value input and cursor disappears.</li> <li>• ENT: After completing configuration, moves cursor to next input. Touch [ENT], cursor moves year, month, day, hour, min, sec in order. When new date type is designated in GP Editor, cursor moves to display order.</li> </ul>
②	Displays current set date and time in real time. Touch to reset item; year, month, day, hour, min, sec, and cursor appears to input.



#### Caution

Designated time is applied for clock, alarm history, alarm list, etc which are related with time.

If external power is cut, current time is maintained by battery. If there is time error with connected external power, battery may be discharged. Please check battery status from [SET ENVIRONMENT]-[BATTERY] of system setting menu.

### 6.4.4 Clear USER DATA

This menu is for initializing user data and setting values of LP. Be sure that once deleted data cannot recover.

Be sure that once deleted data cannot recover.

Especially for saving alarm history contents, by GP Editor upload alarm history and alarm frequency with checking 'Alarm History (Alarmhistory.txt)' and 'Alarm Frequency (Alarmfrequency.txt)' in tag box of 'Monitor Data Upload' dialog box from [Communication]-[Upload] menu to save txt files.

If LP and serial printer is connected, you can print alarm history in [SET FUNCTION] – [PRINT OUT] of system setting menu.



No.	Function and operation
①	Touch 'CLEAR GP DATA' and it initializes every data of screens of LP, part, comment, and common configuration information. After completing initializing, user screen displays 'USER SCREEN IS NOT FOUND' message.
②	Touch 'CLEAR LP DATA' and it deletes ladder program, parameter, device data.



#### Caution

During downloading user-designed data and ladder data, if download is stop in the middle of progressing by power and cable statue, initialize the data of LP and download it again.

### 6.4.5 Menu call key

Check or select the position of system setting menu key to enter from user screen.

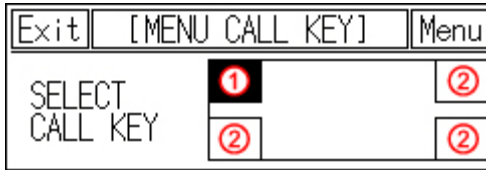

No.	Function and operation
①	Displayed that this position is already designated for system setting menu key.
②	You can designate system setting menu key up to two keys. If two keys for system setting menu is set, you should touch both two keys simultaneously to enter system setting menu.



#### Note

In case screen direction is vertical (bottom side from front screen is placed at left status), default position of system setting menu key is placed at left-upper point.

Touch left-upper point as soon as re-supply power and it enters to system setting menu.

If there is numeral/ASCII input or touch key tag at system setting menu key position, it executes only tag operation and it does not enter system setting menu.

### 6.4.6 Buzzer

Designate buzzer on or off for touch key operation, numeral or ASCII input touch, system setting menu touch, communication start and complete, or alarm.

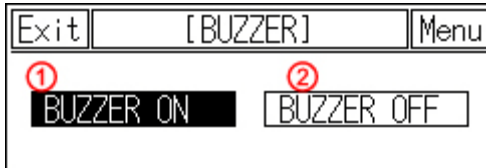

No.	Function and operation
①	Touch this, buzzer turns on. It displays contrast item is not set.
②	Touch this, buzzer turns off.



### 6.4.7 Opening time

Menu for set time of open screen when supplying power.

Exit	[OPENING TIME]			Menu
① 0	1	2	3	OPENING TIME
4	5	6	7	②
8	9	CLR	ENT	SEC

No.	Function and operation
①	Set time of open screen. Set range is from 0 sec to 60 sec. <ul style="list-style-type: none"> <li>0 to 9: Touch the desired time.</li> <li>CLR: Cancel the set input, input cursor disappears.</li> <li>ENT: Set the input value.</li> </ul>
②	Displays the set time for switching from open screen to user screen. Touch the time to reset, input cursor appears to set.



#### Note

Open screen displays to check current basic information(firmware releasing date, and version).

### 6.4.8 Backlight

Designate back light off time.

If there is no touch on screen of LP until off time of backlight, LCD backlight is OFF. Backlight is ON again when user touches it. In this case touching is only for backlight ON and the other operation is not valid.

Exit	[BACKLIGHT]			Menu
① 0	1	2	3	BACKLIGHT OFF
4	5	6	7	②
8	9	CLR	ENT	MIN

No.	Function and operation
①	Designate back light off time if there is no touch input. <ul style="list-style-type: none"> <li>0 to 9: Touch the desired time.</li> <li>CLR: Cancel the set input, input cursor disappears.</li> <li>ENT: Set the input value.</li> </ul> Set range is 0 min to 99min. If 0 is set, backlight is not OFF Depending on the status from [System information device]–[Backlight control bit of read device] in LP, it controls the designated operation. Backlight setting and operation is available only when backlight control device is SET (ON). If backlight control device is RESET (OFF), it does not operate irrespectively menu setting.
②	Displays the set time for back light off. Touch the time to reset, input cursor appears to set.

### 6.4.9 Battery

You can check battery remaining as percentage (%).

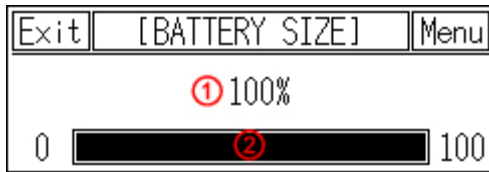

No.	Function and operation
①	Displays battery remaining with bar graph
②	Displays battery remaining with 0 to 100% as numerical percentage.



#### Note

When battery remaining is 0%, 'Bat Low' message flashes.

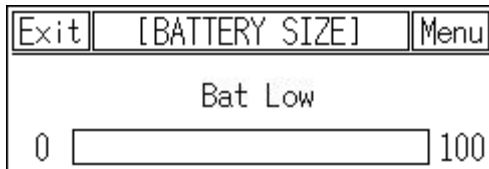

### 6.4.10 Contrast

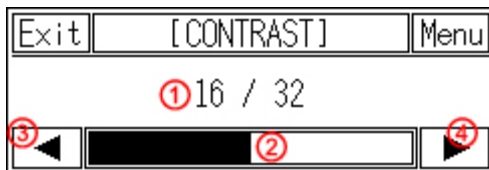

No.	Function and operation
①	Displays current set status.
②	Displays set screen contrast ratio as bar graph.
③	Touch this, it decreases contrast ratio.
④	Touch this, it increases contrast ratio.

## 6.5 Data View

### 6.5.1 Base screen

This menu displays screen number and screen title list for base screen. Touch the desired screen, you can check designed status of the screen.

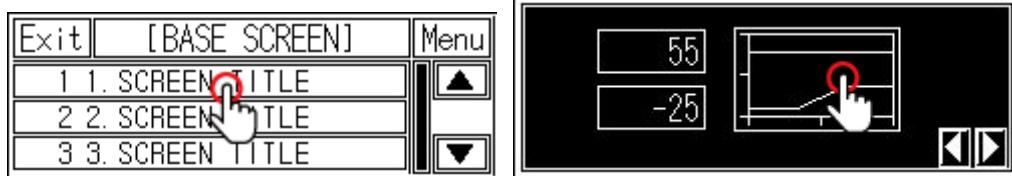

#### Note

By checking base screen from the list, the display object of the selected base screen operates normally but the input object of the selected screen does not operate.

### 6.5.2 Window screen

This menu displays screen number and screen title list for window screen. Screen check method is same as base screen's.

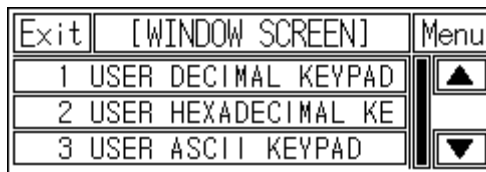

#### Note

Window screen is designed up to 500 from GP Editor but actual downloadable window screens are up to 3 to LP.

### 6.5.3 Comment

This menu displays downloaded user-defined comment.



### 6.5.4 Memory size

This menu displays total disk capacity (512Kbyte) and available capacity of LP.

Exit	[MEMORY SIZE]	Menu
TOTAL MEMORY	:	512Kbyte
USER AREA	:	0Kbyte
AVAILABLE	:	512Kbyte

### 6.5.5 Model & Version

This menu displays LP-S044 model name and firmware version.

Exit	[MODEL & VERSION]	Menu
MODEL NAME : LP-S044-S1D0		
F/W VER : 3.11(NG3100)		
RELEASE : 2010.12.10 12:00		

## 6.6 Set Function

This menu screen is displayed during communicating (download/upload) between GP Editor of PC and LP.

- Waiting

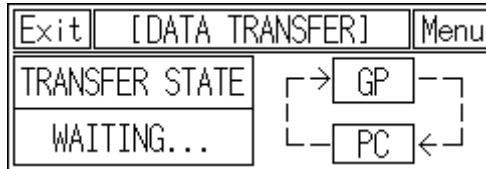

- Download

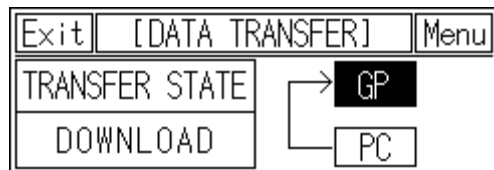
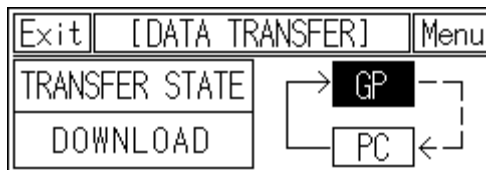

- Upload

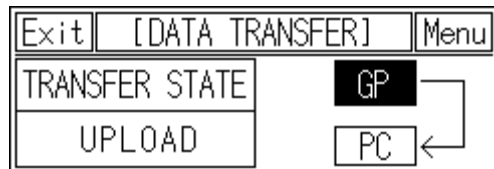
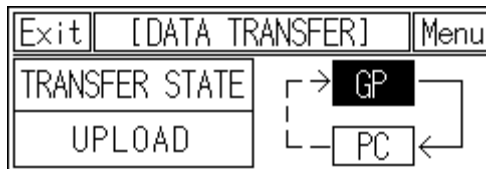

### 6.6.1 Time switch

When the designated time and day of the week, it turns bit device of connected device ON/OFF. Maximum 8 bit devices which have consecutive numbers operate as time switch. It is able to set operation time by each bit device.

Time switch function is also able to set at [Common]-[Time Action] menu of GP Editor.

Not designated ACTION(ACT) item displays action time as [?:?:??:??:?].

Exit	[TIME SWITCH]	Menu	
ACT1 Device	ACT2 Device	ACT3 Device	ACT4 Device
ACT5 Device	ACT6 Device	ACT7 Device	ACT8 Device

No.	Function and operation
①	Action number of time switch.
②	If there is no designated device as time switch bit device, 'Device' is displayed.

Touch this, numeral input key pad appears to input start time and end time.

Exit	[TIME SWITCH]	Menu	
ACT1 Device	ACT2 Device	ACT3 Device	ACT4 Device
ACT5 Device	ACT6 Device	ACT7 Device	ACT8 Device

Exit	[SET ACT 1]	Menu				
SUN	MON	TUE	WED	THU	FRI	SAT
ACT START TIME		②	2:15:00			
ACT END TIME		③	4:17:30			

No.	Function and operation
①	Touch desired day of the week. Shaded item (MON, WED, FRI) are selected.
②	Designate action start time. Touch this, input key pad appears.
③	Designate action end time. Touch this, input key pad appears.

### 6.6.2 Print out

This menu is for printing alarm history which is listed during LP operation by external printer.

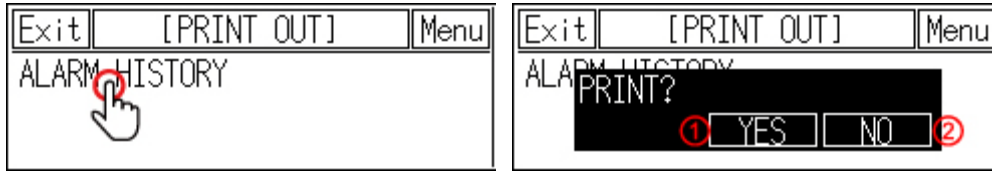

No.	Function and operation
①	Prints alarm history with touching. Printer port setting: From [SET ENVIRONMENT]-[PLC SETTING] of system setting menu, set 'PRINTER'
②	Cancels alarm history output.



**Note**

Alarm history printout format

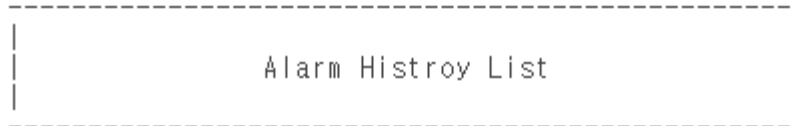

NO	DATE	TIME	MESSAGE
0	12-02-20	09:36:55	A alarm occurs!
1	12-02-20	09:36:57	B alarm occurs!
2	12-02-20	09:37:02	A alarm occurs!

## 6.7 Set parameter

### 6.7.1 Filter

This menu is for displaying the set input filter value at SmartStudio.

For input filter setting, refer to 'SmartStudio user manual'.

- Filter value is not set.

Exit	[SET FILTER]	Menu
X00 - X07	0[Direct]	▲
X08 - X0F	0[Direct]	▼
DEVICE	NO USE	

- Filter value is set at SmartStudio.

Exit	[SET FILTER]	Menu
X00 - X07	①37[11-15ms]	▲
X08 - X0F	②19[8ms]	▼
DEVICE	③M0100	

No.	Function and operation
①	Displays the set X0 to X7 filter values.
②	Displays the set X8 to XF filter values.
③	Displays inner device to save the set filter value.



#### Note

When inner device is set, it is able to control filter value as the designated device.

Change M device for using inner device to filter value. Filter value is available from 0 to 63(6bit). Below table is for actual filter value by filter value. Please refer this for setting filter value.

Filter time(ms)	Actual filter value
0	0
1	1
2	4
3	6
4	9
5	11
6	14

Filter time(ms)	Actual filter value
7	17
8	19
9	22
10	24
15	37
20	52



### 6.7.2 Interrupt

This menu is for displaying the set interrupt at SmartStudio. For interrupt information, refer to 'SmartStudio user manual'.

- Interrupt is not set.

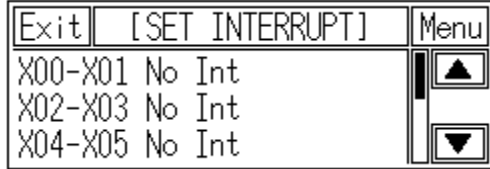

- Interrupt is set at SmartStudio.



No.	Function and operation
①	Displays the set interrupt type of X00-X0F. (No Int, Falling, Rising)
②	Saves the set value at the device by 2 bit 2 WORD in order.



Ex.

This example is that each interrupt set value is mapping to inner device. (In case of setting inner device as M0100)

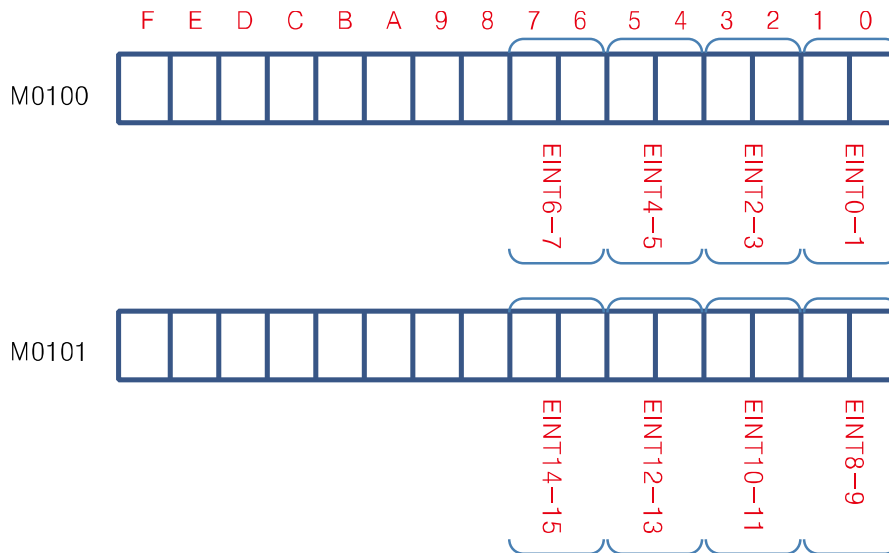

From the logic to change this inner device value on ladder program, it can control filter value. To use inner device, to control interrupt value are same as using filter's.

### 6.7.3 4 X 4 keypad

This menu is for displaying the set keypad(MATRIX) at SmartStudio.  
For 4 X 4 keypad information, refer to 'SmartStudio user manual'.

- Keypad (MATRIX) is not set.



- Keypad (MATRIX) is set at SmartStudio.

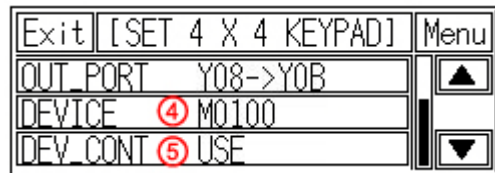
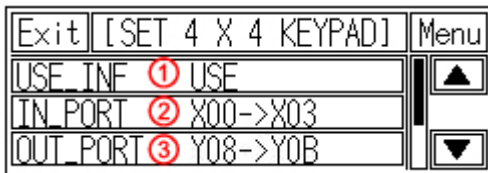

No.	Function and operation
①	Displays whether using keypad (MATRIX).
②	Displays the set input register value.
③	Displays the set output register value.
④	Displays the device to save key input.
⑤	Displays whether using 'Device Extensions'.



**Note**

[Matrix connection diagram]

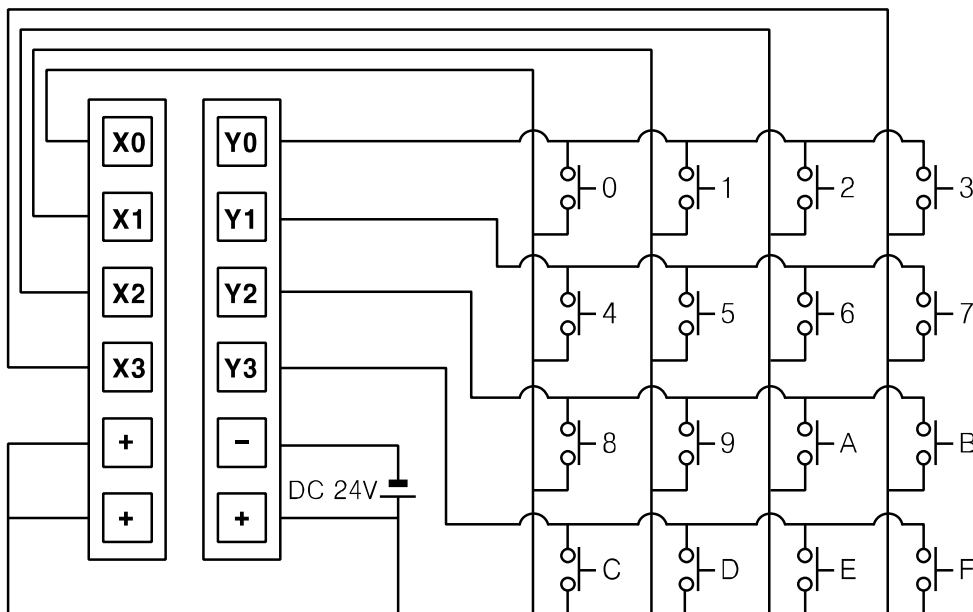



[Save method of input value]

After setting input register as X0 to X3, output register as Y0 to Y3, and device as M0, wire it as above connection diagram. This is the operation description.

When press no. 2, no. 8, no. B keys at the same time;

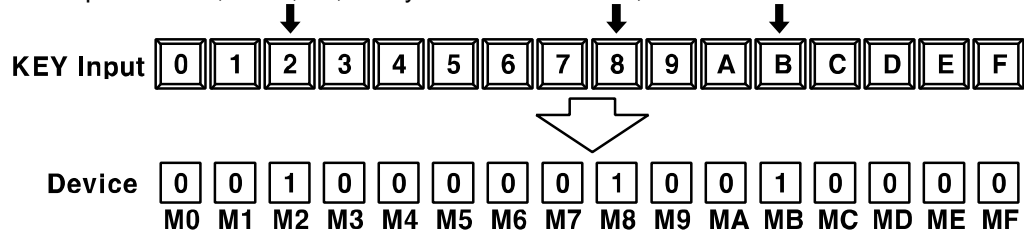

The result of key input is that 2nd, 8th, Bth bit of word device M0 turn ON and M0 value of word device is changed as 0x0904.

### 6.7.4 7 segment display

This menu is for displaying the set 7 segment output data at SmartStudio. For 7 segment information, refer to 'SmartStudio user manual'.

- 7 segment is not set.

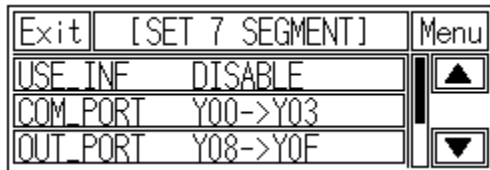

- 7 segment is set at SmartStudio.



No.	Function and operation
①	Displays whether using 7 segment.
②	Displays the set output register (COM) value.
③	Displays the set output register (SEG) value.
④	Displays the set output device.
⑤	Displays whether using 'Device Extensions'.



**Note**

The contents of a device when checking 'Device Extensions'

WDS: word device lead address: The set device in device item in 7 segment setting.

<b>Using device extensions</b>	WDS: [If output register (COM) setting is Y0 to Y03, it saves 0. If output register (COM) setting is Y8 to YB, it saves 1.] WDS+1: [If output register (SEG) setting is Y8 to YF, it saves 0. If output register (SEG) setting is Y0 to Y7, it saves 1.] WDS+2: [First segment output data] WDS+3: [Second segment output data] WDS+4: [Third segment output data] WDS+5: [Fourth segment output data]
<b>Not using device extensions</b>	WDS: [First segment output data] WDS+1: [Second segment output data] WDS+2: [Third segment output data] WDS+3: [Fourth segment output data]

[Setting example and output timing diagram]

Setting item	Setting example
Using 7-segment	Check (Using)
Output Register(COM)	Y00000 – Y00003
Output Register (SEG)	Y00008 → Y0000F
Device	Inputs M0[0x55], M1[0xAA], M2[0xF0], M3[0x0F] as present value

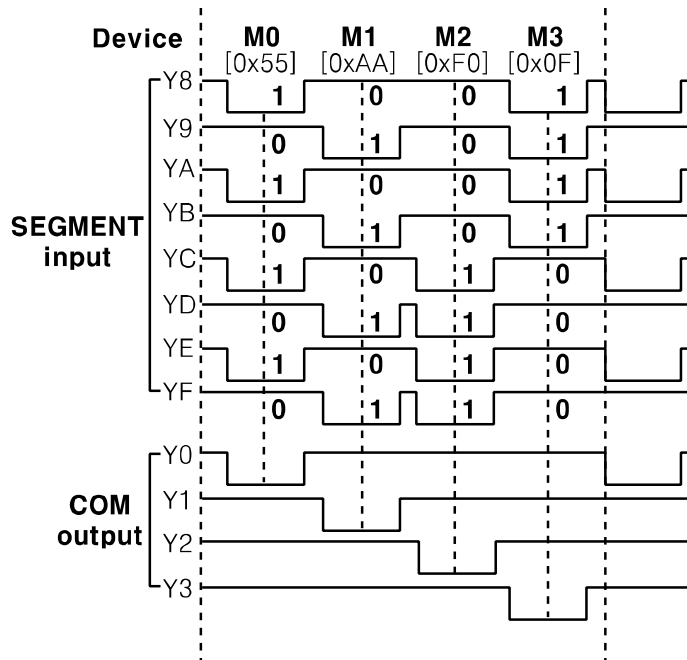

### 6.7.5 Synchronous serial

You can check the set status of synchronous serial output which outputs data by fixed timing with Clock, Data, Latch signal.

This menu is for displaying the set synchronous serial at SmartStudio.  
For synchronous serial information, refer to 'SmartStudio user manual'.

- Synchronous serial (SIO) is not set.

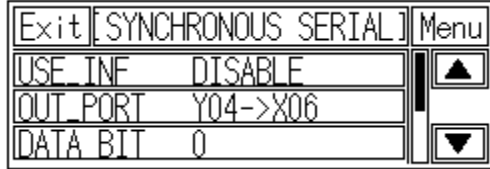

- Synchronous serial (SIO) is set at SmartStudio.

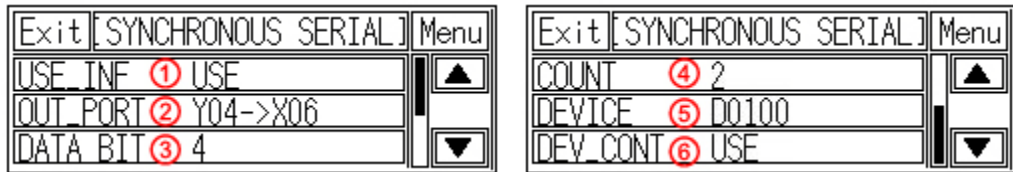

No.	Function and operation
①	Displays whether using synchronous serial (SIO) set.
②	Displays the set output register value.
③	Displays the set data bit.
④	Displays the set number of data.
⑤	Displays the set data lead device.
⑥	Displays whether using 'Device Extensions'.



**Note**

Output data information range varies according to set data bits

Data bit	Available output data range
4 bit	0x000 to 0x000F
5 bit	0x000 to 0x001F
6 bit	0x000 to 0x003F
7 bit	0x000 to 0x007F

The contents of a device when checking 'Device Extensions'

WDS: word device lead address: The set device in device item in SIO setting.

<b>Using device extensions</b>	WDS: [If output register setting is Y4, Y5, and Y6, it saves 0. If output register setting is YC, YD, and YE, it saves 1.] WDS+1: [Saves the set number of data bits] WDS+2: [Saves the set number of data] WDS+3: [1st display data] ... WDS+n: [(n-3)th display data] *n-3: the number of data
<b>Not using device extensions</b>	WDS: [1st display data] ... WDS+n: [(n-3) th display data] *n : the number of data



Ex.

[Setting example and output timing diagram]

Setting item	Setting example
Using SIO	Check (Using)
Output Register	Y00004 – Y00006
Data Bit	4
The Number of Data	3
Device	D0

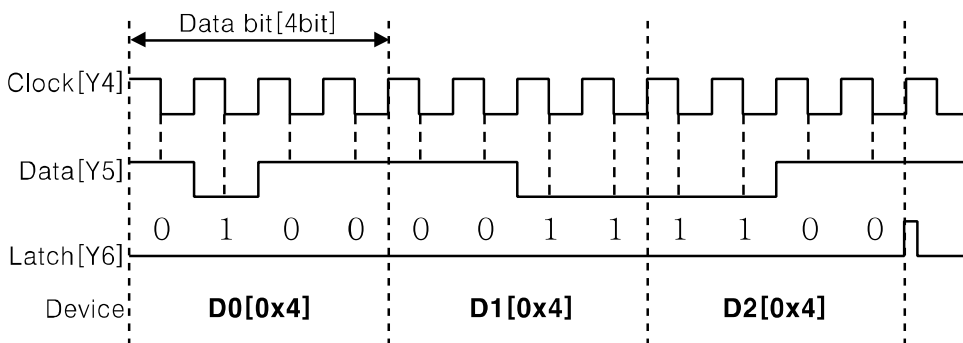

## 7 User Screen

User screen is a base or window screen designed with GP Editor.

### 7.1 Screen specification

#### (1) Base screen size

Base screen size is as entire area of the screen, 240 X 80 dot.

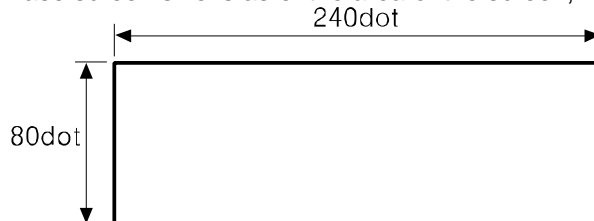

#### (2) Window screen size

Window screen size is min. 16X20dot to max. 240X80dot for LP -S044.

You can designate window screen size and its position in GP Editor, and also assign individual screen number for window screen as base screen number.

#### (3) Screen position

Content	Base screen	Window screen
Start position of screen (left-upper point)	(0,0)	(0, 0) to (239, 79)
End position of screen (right-lower point)	(239, 79)	(15, 19) to (239, 79)
Position by screen type	Base screen size is not changeable and has fixed coordinate value.	If window screen is over maximum size, right- lower point moves automatically to the end point of screen. Therefore, it may different between user-defined position and window screen position.

#### (4) Screen number and the number of screen

Item	Base screen	Window screen
Screen number	Enable to designate from 1 to 500 range	
The number of designable screen	500	
The number of downloadable screen	500 ※ <sup>1</sup>	3 ※ <sup>2</sup>

※1. If designed base screen capacity is over user data area, data transmission does not operates normally. Please check designed data capacity and download it again.

※2. Designed window screen is for user-defined key pad. In this case, maximum number of downloadable screen to LP is 3.

## 7.2 Screen display object

### (1) Available display object by screen type

	Base screen	Window screen
Available display object	Line, rectangle, circle, text, bitmap, numeral display, ASCII display, numeral input <sup>※1</sup> , ASCII input <sup>※1</sup> , clock, comment list, alarm history <sup>※1</sup> , alarm list <sup>※1</sup> , part display, lamp display, line graph, trend graph, bar graph, statistic graph, panel meter, touch key	Line, rectangle, circle, text, bitmap, numeral display, ASCII display, display clock, comment list, part display, lamp display, line graph, trend graph, bar graph, statistic graph, panel meter, touch key

※1. These are displayed only on base screen.

### (2) Limit the number of display objects by screen type

Except below some objects, there is no limit the number of displaying for all tags on screen. However, too many objects on a screen may cause reducing monitor speed remarkably.

- Object which can exist only one on a screen:  
Alarm history, alarm list with scroll option, trend graph, and line graph
- Object which cannot exist on a screen:  
Alarm history, alarm list with scroll option, trend graph and line graph

### (3) Limit the number of display objects by project

It is available to use objects with memory store function (trend graph, alarm list) on a project max.16.



## 7.3 Screen switching

### (1) Screen switching device

The designed user screen in GP Editor has own number and it is downloaded to LP, LP monitors base screen switching device periodically and decides to be displayed base screen. Screen switching device is designated in GP Editor. It recognizes the current value of device assigned to switching device of base screen as screen number, it is displayed the screen. In order to make same as the real screen number and device reference value for screen access, it is designed to display screen no.1 when the current value of device is '0'.

[Operation when D0 [Current value] device as base screen number device]

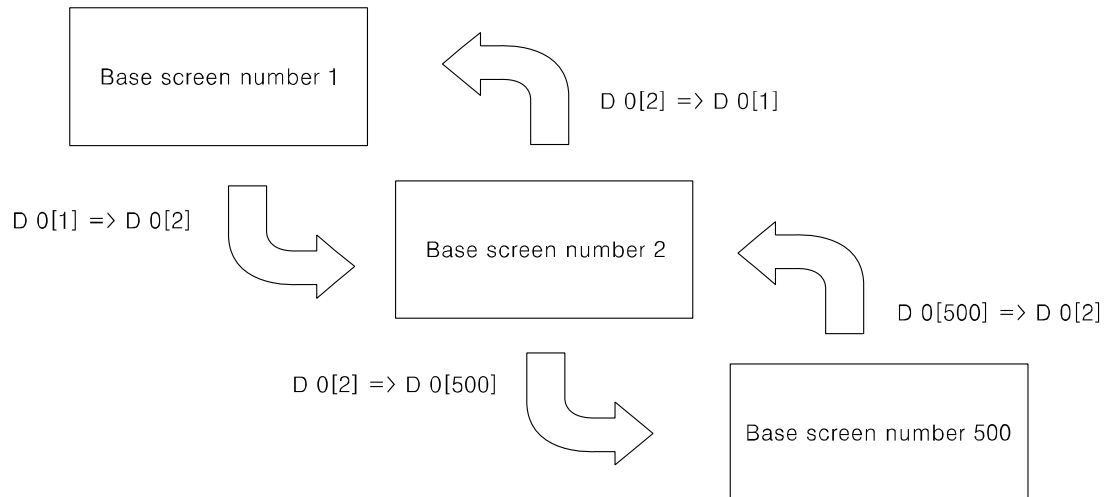

If there is no screen number corresponding the device value of screen data, error message appears

### (2) Screen switching methods

It is switched to the appropriate screen when changing screen switching device value. It is changed as below methods.

- 1) Using touch key for switching screen
 

There are switching functions of touch key operations as follows.

  - ◆ Switching to the fixed screen
  - ◆ Switching to the previous screen
  - ◆ Switching to the adjacent lower number of screen
  - ◆ Switching to the adjacent upper number of screen
- 2) Numeral input
 

It is switched to the appropriate screen inputting screen number in screen switching device using numeral input tag.
- 3) Device monitor
 

It is switched from device on device monitor of system screen to the appropriate screen inputting the value in screen switching.
- 4) Screen switching a screen by PLC program
 

When changing a screen switching device on PLC program, LP switches it into the appropriate screen.

## 7.4 Overlap window function

LP monitors user-defined of 2 screen overlap devices and overlaps the screen satisfying current value of the device on a base screen.

In order to use screen overlap function, designate the device for overlap window in GP Editor.

The overlap window is displayed in order of window 1, 2 on current screens as below. In case, the value of overlap window device is exceeded the range (1 to 500) or does not exist, the window is not displayed.

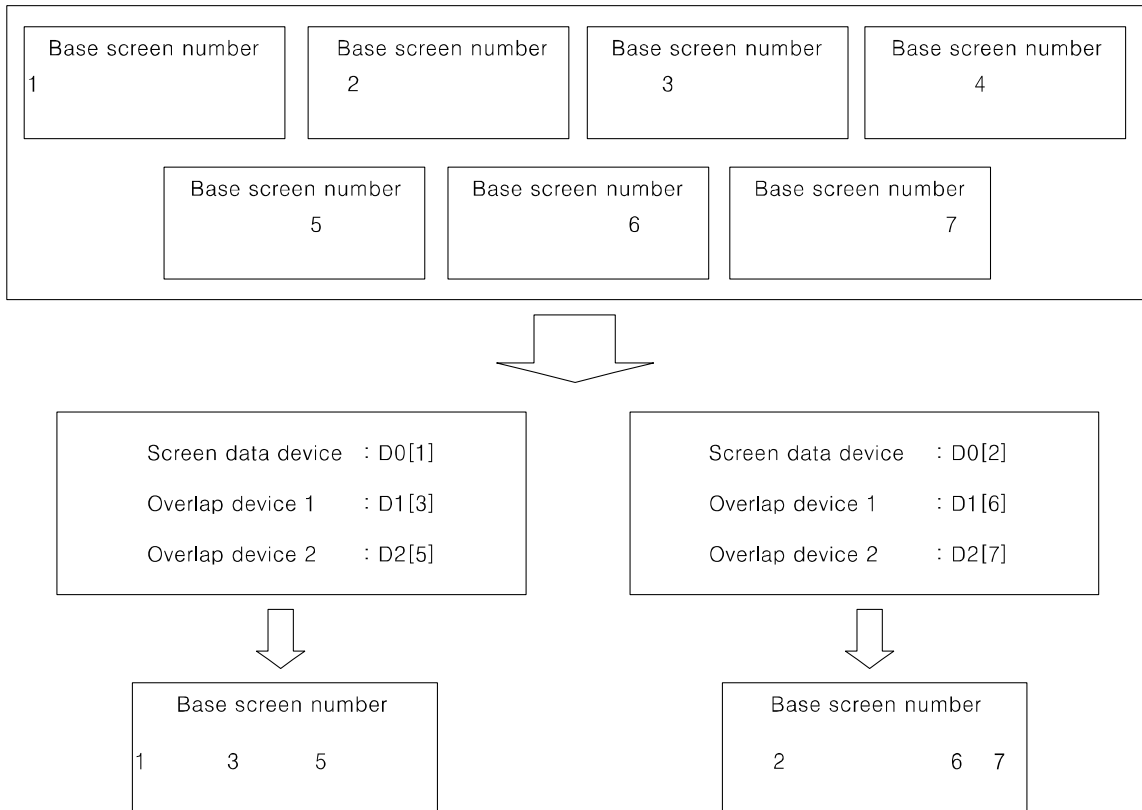



Ex.

It discibes when screen calling device is D 0, overlap window 1 device is D 1, overlap window 2 device is D 2.

**All user-defined base screen numbers: 1, 2, 3, 4, 5, 6, 7, 8**

- In case of D0=1, D1=3, D2=11,

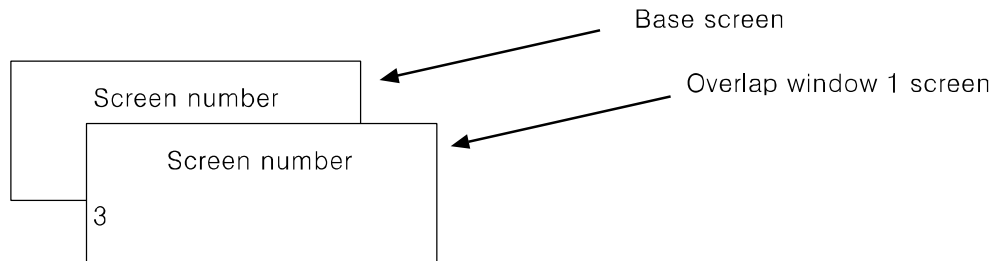

Overlap window 2 is not overlapped because the value of overlap window 2 device is not an existing base screen number.

- In case of D0=1, D1=3, D2=5,

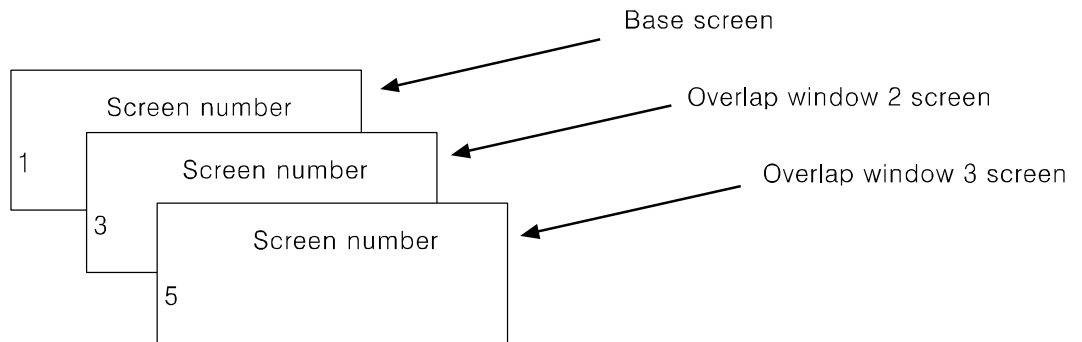

**Caution**

Various tags of overlap screen in the upper part can cover lower part of tags and they are not shown. If touch keys or input tags are overlapped, the upper one is only operated when it touched.

## 7.5 Device connection status display

If configured connect device is not connected or connection has error, at [SYSTEM SETTING] - [SET ENVIRONMENT] - [PLC SETTING] menu displays error message as following screen.



Touch 'CLOSE' and error message dialog box disappears. If connection error is not resolved after 5 seconds, error message appears again on the screen.



### Caution

Connection error message appears only on user screen.

When the third (CH1), fourth (CH2) bit of system signal 1 device in system information device are ON status, error message for specified connect device appears on the screen.

For more details, refer to 'GP Editor user manual'.

# 8 System Window

## 8.1 Keypad type

No	Type	Keypad screen																																													
1	Binary	<table border="1"> <tr> <td colspan="4"></td> <td>CLR</td> </tr> <tr> <td colspan="4"></td> <td>▲</td> </tr> <tr> <td colspan="4"></td> <td>▼</td> </tr> <tr> <td>0</td> <td>1</td> <td>BS</td> <td>ENT</td> <td></td> </tr> </table>					CLR					▲					▼	0	1	BS	ENT																										
				CLR																																											
				▲																																											
				▼																																											
0	1	BS	ENT																																												
2	Octal	<table border="1"> <tr> <td colspan="4"></td> <td>CLR</td> </tr> <tr> <td colspan="4"></td> <td>▲</td> </tr> <tr> <td colspan="4"></td> <td>▼</td> </tr> <tr> <td>0</td> <td>1</td> <td>2</td> <td></td> <td></td> </tr> <tr> <td>3</td> <td>4</td> <td>5</td> <td></td> <td></td> </tr> <tr> <td>6</td> <td>7</td> <td>BS</td> <td>ENT</td> <td></td> </tr> </table>					CLR					▲					▼	0	1	2			3	4	5			6	7	BS	ENT																
				CLR																																											
				▲																																											
				▼																																											
0	1	2																																													
3	4	5																																													
6	7	BS	ENT																																												
3	Decimal	<table border="1"> <tr> <td colspan="4"></td> <td>CLR</td> </tr> <tr> <td colspan="4"></td> <td>▲</td> </tr> <tr> <td colspan="4"></td> <td>▼</td> </tr> <tr> <td>0</td> <td>1</td> <td>2</td> <td>3</td> <td></td> </tr> <tr> <td>4</td> <td>5</td> <td>6</td> <td>7</td> <td></td> </tr> <tr> <td>8</td> <td>9</td> <td>-</td> <td>BS</td> <td>ENT</td> </tr> </table>					CLR					▲					▼	0	1	2	3		4	5	6	7		8	9	-	BS	ENT															
				CLR																																											
				▲																																											
				▼																																											
0	1	2	3																																												
4	5	6	7																																												
8	9	-	BS	ENT																																											
4	Hexadecimal	<table border="1"> <tr> <td colspan="4"></td> <td>0</td> <td>1</td> <td>CLR</td> </tr> <tr> <td colspan="4"></td> <td>▲</td> <td></td> <td></td> </tr> <tr> <td colspan="4"></td> <td>▼</td> <td></td> <td></td> </tr> <tr> <td>2</td> <td>3</td> <td>4</td> <td>5</td> <td>6</td> <td></td> <td></td> </tr> <tr> <td>7</td> <td>8</td> <td>9</td> <td>A</td> <td>B</td> <td></td> <td></td> </tr> <tr> <td>C</td> <td>D</td> <td>E</td> <td>F</td> <td>BS</td> <td>ENT</td> <td></td> </tr> </table>					0	1	CLR					▲							▼			2	3	4	5	6			7	8	9	A	B			C	D	E	F	BS	ENT				
				0	1	CLR																																									
				▲																																											
				▼																																											
2	3	4	5	6																																											
7	8	9	A	B																																											
C	D	E	F	BS	ENT																																										
5	Real number	<table border="1"> <tr> <td colspan="4"></td> <td>CLR</td> </tr> <tr> <td colspan="4"></td> <td>▲</td> </tr> <tr> <td colspan="4"></td> <td>▼</td> </tr> <tr> <td>0</td> <td>1</td> <td>2</td> <td>3</td> <td>4</td> </tr> <tr> <td>5</td> <td>6</td> <td>7</td> <td>8</td> <td>9</td> </tr> <tr> <td>.</td> <td>EXP</td> <td>-</td> <td>BS</td> <td>ENT</td> </tr> </table>					CLR					▲					▼	0	1	2	3	4	5	6	7	8	9	.	EXP	-	BS	ENT															
				CLR																																											
				▲																																											
				▼																																											
0	1	2	3	4																																											
5	6	7	8	9																																											
.	EXP	-	BS	ENT																																											
6	ASCII	<table border="1"> <tr> <td colspan="4"></td> <td>CLR</td> </tr> <tr> <td colspan="4"></td> <td>▲</td> </tr> <tr> <td colspan="4"></td> <td>▼</td> </tr> <tr> <td>S</td> <td>!</td> <td>"</td> <td>#</td> <td>\$</td> <td>%</td> <td>&amp;</td> <td>'</td> <td>(</td> <td>)</td> </tr> <tr> <td>*</td> <td>+</td> <td>,</td> <td>-</td> <td>.</td> <td>/</td> <td>0</td> <td>1</td> <td>2</td> <td>3</td> </tr> <tr> <td>4</td> <td>5</td> <td>6</td> <td>7</td> <td>◀</td> <td>▶</td> <td>BS</td> <td>ENT</td> <td></td> <td></td> </tr> </table>					CLR					▲					▼	S	!	"	#	\$	%	&	'	(	)	*	+	,	-	.	/	0	1	2	3	4	5	6	7	◀	▶	BS	ENT		
						CLR																																									
						▲																																									
						▼																																									
S	!	"	#	\$	%	&	'	(	)																																						
*	+	,	-	.	/	0	1	2	3																																						
4	5	6	7	◀	▶	BS	ENT																																								
<table border="1"> <tr> <td colspan="4"></td> <td>CLR</td> </tr> <tr> <td colspan="4"></td> <td>▲</td> </tr> <tr> <td colspan="4"></td> <td>▼</td> </tr> <tr> <td>P</td> <td>Q</td> <td>R</td> <td>S</td> <td>T</td> <td>U</td> <td>V</td> <td>W</td> <td>X</td> <td>Y</td> </tr> <tr> <td>Z</td> <td>[</td> <td>]</td> <td>^</td> <td>_</td> <td>`</td> <td>a</td> <td>b</td> <td>c</td> <td></td> </tr> <tr> <td>d</td> <td>e</td> <td>f</td> <td>g</td> <td>◀</td> <td>▶</td> <td>BS</td> <td>ENT</td> <td></td> <td></td> </tr> </table>					CLR					▲					▼	P	Q	R	S	T	U	V	W	X	Y	Z	[	]	^	_	`	a	b	c		d	e	f	g	◀	▶	BS	ENT				
				CLR																																											
				▲																																											
				▼																																											
P	Q	R	S	T	U	V	W	X	Y																																						
Z	[	]	^	_	`	a	b	c																																							
d	e	f	g	◀	▶	BS	ENT																																								
<table border="1"> <tr> <td colspan="4"></td> <td>CLR</td> </tr> <tr> <td colspan="4"></td> <td>▲</td> </tr> <tr> <td colspan="4"></td> <td>▼</td> </tr> <tr> <td>8</td> <td>9</td> <td>:</td> <td>;</td> <td>&lt;</td> <td>=</td> <td>&gt;</td> <td>?</td> <td>@</td> <td>A</td> </tr> <tr> <td>B</td> <td>C</td> <td>D</td> <td>E</td> <td>F</td> <td>G</td> <td>H</td> <td>I</td> <td>J</td> <td>K</td> </tr> <tr> <td>L</td> <td>M</td> <td>N</td> <td>O</td> <td>◀</td> <td>▶</td> <td>BS</td> <td>ENT</td> <td></td> <td></td> </tr> </table>					CLR					▲					▼	8	9	:	;	<	=	>	?	@	A	B	C	D	E	F	G	H	I	J	K	L	M	N	O	◀	▶	BS	ENT				
				CLR																																											
				▲																																											
				▼																																											
8	9	:	;	<	=	>	?	@	A																																						
B	C	D	E	F	G	H	I	J	K																																						
L	M	N	O	◀	▶	BS	ENT																																								
<table border="1"> <tr> <td colspan="4"></td> <td>CLR</td> </tr> <tr> <td colspan="4"></td> <td>▲</td> </tr> <tr> <td colspan="4"></td> <td>▼</td> </tr> <tr> <td>h</td> <td>i</td> <td>j</td> <td>k</td> <td>l</td> <td>m</td> <td>n</td> <td>o</td> <td>p</td> <td>q</td> </tr> <tr> <td>r</td> <td>s</td> <td>t</td> <td>u</td> <td>v</td> <td>w</td> <td>x</td> <td>y</td> <td>z</td> <td>{</td> </tr> <tr> <td> </td> <td>}</td> <td>~</td> <td>de</td> <td>◀</td> <td>▶</td> <td>BS</td> <td>ENT</td> <td></td> <td></td> </tr> </table>					CLR					▲					▼	h	i	j	k	l	m	n	o	p	q	r	s	t	u	v	w	x	y	z	{		}	~	de	◀	▶	BS	ENT				
				CLR																																											
				▲																																											
				▼																																											
h	i	j	k	l	m	n	o	p	q																																						
r	s	t	u	v	w	x	y	z	{																																						
	}	~	de	◀	▶	BS	ENT																																								

## 8.2 Keypad organization

											CLR
S	!	"	#	\$	%	&	'	(	)		▲
*	+	,	-	.	/	0	1	2	3		▼
4	5	6	7	←	→	BS	ENT				

KEY	Operation
ENT	Writes or inputs writing value on device.
CLR	Deletes all input value.
BS	Deletes latest input.
▲	Moves to the previous input field in accordance with configuration.
▼	Moves to the next input field in accordance with configuration.
←*1	Moves to the previous page.
→*1	Moves to the next page.

\*1 Those keys are displayed only for ASCII input key pad.

ENT, CLR, ▲, ▼ key operation of user screen is according to 'Key Action' settings of 'Screen Auxiliary Configuration' dialog box.

Key operation	CLR	ENT	▲	▼
No movement	Holds keypad	Holds keypad	Not operated	Not operated
In order of user ID	Holds keypad	Holds keypad	Moves to previous input tag	Moves to next input tag
Hide cursor and key window	Closes keypad	Closes keypad	Moves to previous input tag	Moves to next input tag

## 9 Troubleshooting

This chapter is for possible errors in using LP-S044, for diagnosis method by several errors and for troubleshootings.

No	Error description	Troubleshooting (Further details, refer to additional description)
1	Power LED turns OFF.	Troubleshooting in power LED turning OFF.
2	Mode and status LED displays error.	Troubleshooting in error status.
3	External input value has error.	Troubleshooting in error for external input
4	External output value has error.	Troubleshooting in error for external output
5	There is error for writing, reading, or monitoring program.	Troubleshooting in communication connection error.

### (1) Troubleshooting in power LED turning OFF

Check as following list by number. If error is not solved, please notify this to our service center.

No	Check item	Error
1	Is power supplied?	
2	Is supplied power within the allowable voltage range?	
3	Is the polarity of power line wiring correct?	
4	Is there a problem to tighten power terminal?	

### (2) Troubleshooting in error status

Check item	Error checking	Troubleshooting
Program grammar error	F0030, F0034 ON	Correct program grammar in SmartStudio and re-download the program.
Time-driven operation error	F0030, F0035 ON	Notify this to our service center.
Time setting error	F0030, F0036 ON	Reset time setting. (Refer to time setting and time compensation function.)
Communication error	F0030, F0038 ON	Refer to '(5) Troubleshooting in communication connection error' of next page.
I/O setting error	F0030, F0039 ON	Check extension module I/O setting.
WDT error	F0030, F003A ON	Restarts program.

**(3) Troubleshooting in error for external input**

Check as following list by number. If error is not solved, please notify this to our service center.

No	Check item	Error
1	Is input wiring connection correct?	
2	Is connection status of input connector fine?	
3	In case of removing connected input device and connecting COM port of input terminal to input port, is input value entered correctly?※ <sup>1</sup>	
4	Is there a problem to input device operation?	

※1. You can check input value in monitoring function of LP-S044 or in SmartStudio.

**(4) Troubleshooting in error for external output**

Check as following list by number. If error is not solved, please notify this to our service center.

No	Check item	Error
1	Is output wiring connection correct?	
2	Is connection status of output connector fine?	
3	Is connected power voltage to output within allowable voltage range?	
4	Is there problem to output device operation?	

**(5) Troubleshooting in communication connection error**

Check as following list by number. If error is not solved, please notify this to our service center.

No	Check item	Error
1	Do you designate communication configuration (baudrate, data bit, stop bit, and parity) correctly?	
2	Is the specification and wiring of communication cable rated at our specification?※ <sup>1</sup>	

※1. For connect LP-S044, external device and PC, you must use the provided cable (sold separately).



## 10 Firmware update

You can update firmware periodically if necessary.  
Firmware update is available by GP Editor or SmartStudio.



### Caution

In case that LP type is RS-232C A, RS-232C B port, RS-232C B port is available for firmware download. In case that LP type is RS-232C, RS-422 port, RS-232C port is available for firmware download.

### 10.1 Firmware update by GP Editor

1st Firmware file is different as GP/LP model. Download a LP-S044 firmware file from [www.autonics.com](http://www.autonics.com).

You can download only for same firmware GP/LP type with GP/LP type designated at GP Editor. Select [Common]-[GP/PLC Type] of menu, 'GP/PLC Type' dialog box appears. By pull-down menu, designate to be downloaded GP/LP type.

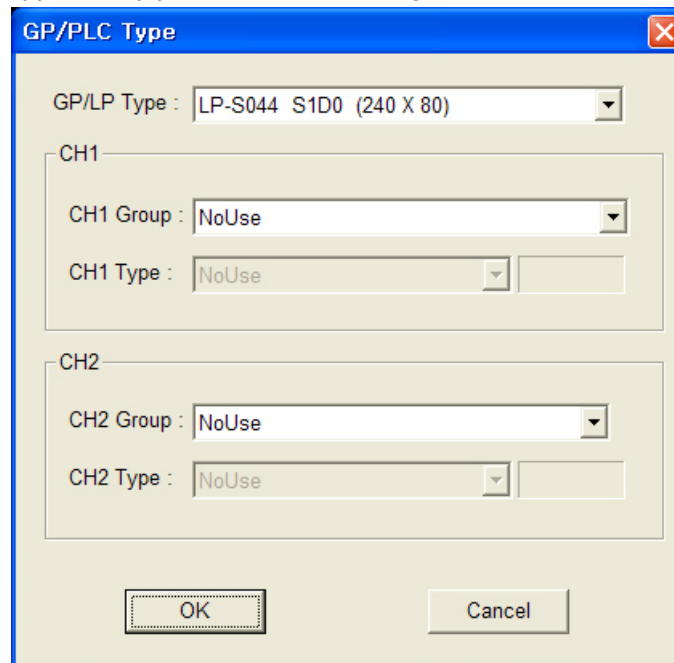

2nd Select [Communication]-[GP Firmware Download] of menu and 'GP Firmware Download' dialog box appears.

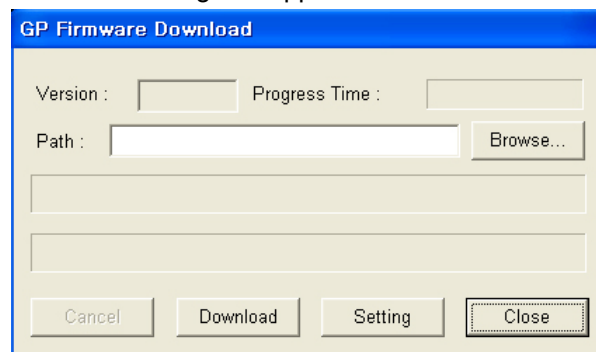

3rd Click 'Browse' and select firmware file to be downloaded.

- 4th Click 'Download' and the firmware information dialog box for current GP/LP firmware appears and asks whether to download or not. If connected GP/LP is not same as the designated GP/LP type from [Common]-[GP/PLC Type] of menu, error message appears.

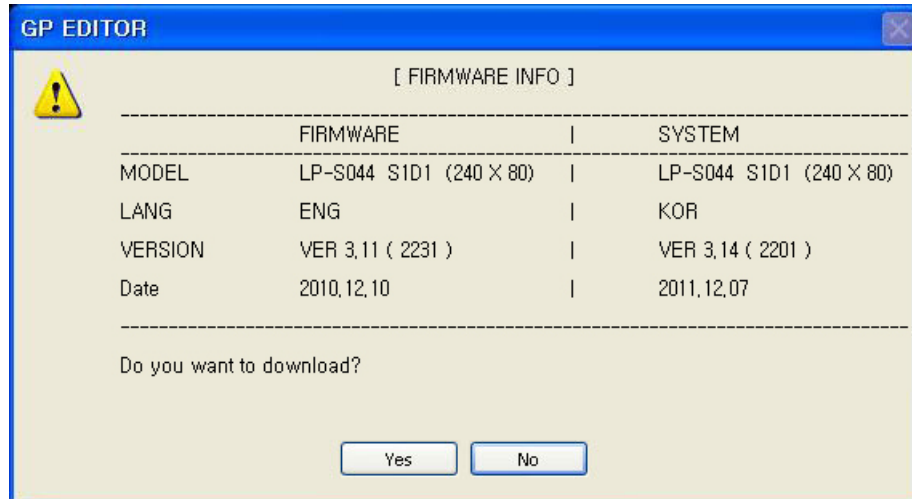

- 5th Click 'Yes' and GP/LP screen displays 'GP FIRMWARE UPGRADE' message. GP Editor displays 'GP Firmware Download' dialog box and download progresses.

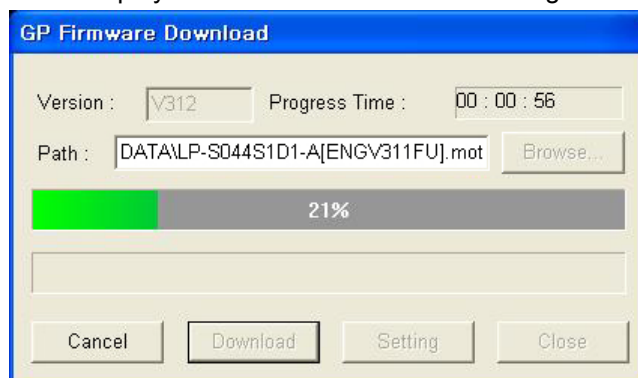

If you want to discontinue download, click 'Cancel' and 'Do you want to interrupt firmware download?' message appears. Click 'Yes' and it discontinues download. For discontinuing download, re-start GP/LP.



- 6th When completing download successively, GP/LP displays 'UPGRADE OK PLEASE POWER OFF' message.
- 7th When failing download, GP/LP displays 'UPGRADE NG PLEASE POWER OFF' message. Re-start GP/LP. GP/LP maintains before firmware version and it does not affect to GP/LP operation.



Do not turn OFF LP-S044 power during firmware update.

## 10.2 Firmware update by SmartStudio

1st Start SmartStudio.

2nd Create new project for to be firmware upgraded LP type.

(Two of RS-232C: LP-S044 S1D1, Each of RS232C/RS422: LP-S044 S1D0)

3rd Select [Online]-[Firmware Download] in SmartStudio.

Following steps are as same as that of firmware update by GP Editor's from 2nd step.



## 11 Repair and Check

### 11.1 Battery change

Battery of LP-S044 is available for maintain user-defined setting, data backup of latch area, and time if there is unexpected power failure or it is not able to supply power. You need to change battery regularly.

#### (1) The status with discharged battery

- When time is not correct.
- After power failure, time is reset.
- After power failure, data of latch area is reset.

#### (2) Battery residual quantity display

You can check battery remaining from [SETENVIRONMENT] - [BATTERY] of system setting menu in LP-S044. Please replace battery if battery remaining is below 5%.

#### (3) Special register for battery

Current backup battery error [F0002C]	Turns ON when battery voltage is below than standard value
Maintain backup battery error [F0002D]	If current backup battery error turns ON at once, it maintains ON status before restarting LP-S044

## 11.2 Check

### 11.2.1 General check

The following table is for checking by every day/week.

Item	Description	Standard	Troubleshooting
Environment	Temperature	0 to 50°C	Adjust the ambient temperature
	Humidity	35 to 85%RH	Adjust the ambient humidity
	Vibration	No vibration	Establish vibration protection
Mounting status of LP-S044	Check screw loosening for bracket	It should be mounted without a shaken.	Tight the screw.
Connection status of communication cable	Check screw loosening of connection cable	Cable connection part should be tightened.	Tight the screw. Use the standard cable
Connection status of I/O connector	Check whether connector locking or not, check connection of connector.	Connection part for connector should be connected tightly.	Secure locking part. Wire connect cable with duct, etc.

### 11.2.2 Periodic check

The following table is for checking by every month.

Item	Description	Standard	Troubleshooting
Power voltage	Measure power voltage	Within power voltage specification	Change supply power
Battery	Battery remaining status	Battery remaining 95%	Change battery
Waterproof rubber ring	Waterproof rubber ring status	Waterproof rubber ring should not be corroded.	Change waterproof rubber ring
Water leak and dusk proof	Water leak and dusk proof status	There is no water leaking, and no dust.	Establish water leak and dust protection
Inflammability gas	Leak inflammability gas	It should not be exposed at inflammability gas.	Establish leak inflammability gas protection

**Caution**

Caution for periodic check

- For checking power voltage, use the specified measuring device.
- If there are error elements, please write down the error and notify us with details.
- For changing the product, power must be turned OFF.
- For removing dust, foreign substance, use dry cloth without moist, or detergents.





## 12 Appendix

### 12.1 Self-diagnosis code table

- Display self diagnosis error code: It saves error codes which correspond with error lamp flash and appropriate module code.
- Self diagnosis code: When operating PLC program, it executes 'refresh input-executing program-refresh output-self diagnosis' repeatedly. The latest detected error is displayed (UW6540) to self error code special device[F140] according to following error code during executing self-diagnosis.

UW6540 (F140)	Type	Cause of error
0X0010	Watchdog error	Scan time exceeds watchdog timer setting value
0X0020	Memory error	When a certain area of memory is the un-approached state.
0x0021	Battery error	When battery value is below the standard level
0x0022	RTC setting error	Disable to set RTC and RTC operation error
0X0030	Program instruction error	When the program contains instructions that are not able to read and inappropriate forms.
0X0031	Program sequence error	When there is not the instructions required to process the program, such as user defined functions, label name, END, RET and IRET, etc.
0X0040	Parameter setting error	When there are some problems in settings for common and expansion parameters.
0X0041	Time-driven error	When it operates longer than the given time-driven run-time.
0X0050	Extended module setting error	In case the hardware constructions are different from previous parameter settings when applying power again and changing the mode.
0X0051	Extended module attaching and removing error	When the extended module is attached or removed in run mode.
0x0060	Communication fail error	When it is received NAK and data format not able to read.
0x0061	Communication format error	When there are some problems occurred in formats (excess of limited range etc.) and CHECK SUM while download and upload.

## 12.2 ASCII code table

Dec	Hx	Oct	Char	Dec	Hx	Oct	Html	Chr	Dec	Hx	Oct	Html	Chr	Dec	Hx	Oct	Html	Chr
0	0	000	<b>NUL</b> (null)	32	20	040	##32;	Space	64	40	100	##64;	@	96	60	140	##96;	`
1	1	001	<b>SOH</b> (start of heading)	33	21	041	##33;	!	65	41	101	##65;	A	97	61	141	##97;	a
2	2	002	<b>STX</b> (start of text)	34	22	042	##34;	"	66	42	102	##66;	B	98	62	142	##98;	b
3	3	003	<b>ETX</b> (end of text)	35	23	043	##35;	#	67	43	103	##67;	C	99	63	143	##99;	c
4	4	004	<b>EOT</b> (end of transmission)	36	24	044	##36;	\$	68	44	104	##68;	D	100	64	144	##100;	d
5	5	005	<b>ENQ</b> (enquiry)	37	25	045	##37;	%	69	45	105	##69;	E	101	65	145	##101;	e
6	6	006	<b>ACK</b> (acknowledge)	38	26	046	##38;	&	70	46	106	##70;	F	102	66	146	##102;	f
7	7	007	<b>BEL</b> (bell)	39	27	047	##39;	'	71	47	107	##71;	G	103	67	147	##103;	g
8	8	010	<b>BS</b> (backspace)	40	28	050	##40;	(	72	48	110	##72;	H	104	68	150	##104;	h
9	9	011	<b>TAB</b> (horizontal tab)	41	29	051	##41;	)	73	49	111	##73;	I	105	69	151	##105;	i
10	A	012	<b>LF</b> (NL line feed, new line)	42	2A	052	##42;	*	74	4A	112	##74;	J	106	6A	152	##106;	j
11	B	013	<b>VT</b> (vertical tab)	43	2B	053	##43;	+	75	4B	113	##75;	K	107	6B	153	##107;	k
12	C	014	<b>FF</b> (NP form feed, new page)	44	2C	054	##44;	,	76	4C	114	##76;	L	108	6C	154	##108;	l
13	D	015	<b>CR</b> (carriage return)	45	2D	055	##45;	-	77	4D	115	##77;	M	109	6D	155	##109;	m
14	E	016	<b>SO</b> (shift out)	46	2E	056	##46;	.	78	4E	116	##78;	N	110	6E	156	##110;	n
15	F	017	<b>SI</b> (shift in)	47	2F	057	##47;	/	79	4F	117	##79;	O	111	6F	157	##111;	o
16	10	020	<b>DLE</b> (data link escape)	48	30	060	##48;	0	80	50	120	##80;	P	112	70	160	##112;	p
17	11	021	<b>DC1</b> (device control 1)	49	31	061	##49;	1	81	51	121	##81;	Q	113	71	161	##113;	q
18	12	022	<b>DC2</b> (device control 2)	50	32	062	##50;	2	82	52	122	##82;	R	114	72	162	##114;	r
19	13	023	<b>DC3</b> (device control 3)	51	33	063	##51;	3	83	53	123	##83;	S	115	73	163	##115;	s
20	14	024	<b>DC4</b> (device control 4)	52	34	064	##52;	4	84	54	124	##84;	T	116	74	164	##116;	t
21	15	025	<b>NAK</b> (negative acknowledge)	53	35	065	##53;	5	85	55	125	##85;	U	117	75	165	##117;	u
22	16	026	<b>SYN</b> (synchronous idle)	54	36	066	##54;	6	86	56	126	##86;	V	118	76	166	##118;	v
23	17	027	<b>ETB</b> (end of trans. block)	55	37	067	##55;	7	87	57	127	##87;	W	119	77	167	##119;	w
24	18	030	<b>CAN</b> (cancel)	56	38	070	##56;	8	88	58	130	##88;	X	120	78	170	##120;	x
25	19	031	<b>EM</b> (end of medium)	57	39	071	##57;	9	89	59	131	##89;	Y	121	79	171	##121;	y
26	1A	032	<b>SUB</b> (substitute)	58	3A	072	##58;	:	90	5A	132	##90;	Z	122	7A	172	##122;	z
27	1B	033	<b>ESC</b> (escape)	59	3B	073	##59;	;	91	5B	133	##91;	[	123	7B	173	##123;	{
28	1C	034	<b>FS</b> (file separator)	60	3C	074	##60;	<	92	5C	134	##92;	\	124	7C	174	##124;	
29	1D	035	<b>GS</b> (group separator)	61	3D	075	##61;	=	93	5D	135	##93;	]	125	7D	175	##125;	}
30	1E	036	<b>RS</b> (record separator)	62	3E	076	##62;	>	94	5E	136	##94;	^	126	7E	176	##126;	~
31	1F	037	<b>US</b> (unit separator)	63	3F	077	##63;	?	95	5F	137	##95;	_	127	7F	177	##127;	DEL

### 12.3 UW correspondence table

	Description	Bit range	Word range	GP device(UB)	GP device (UW)
X	Input device	X0 to X255F	X0 to X255	UB70000 to UB7255F	UW7000 to UW7255
Y	Output device	Y0 to Y255F	Y0 to Y255	UB80000 to UB8255F	UW8000 to UW8255
M	Auxiliary device	M0 to M9999F	M0 to M9999	UB200000 to UB29999F	UW20000 to UW29999
S	Step device	S0.0 to S255.99			
D	Data device	D0 to D9999F	D0 to D9999		UW40000 to UW49999
T	Timer contact	T0 to T255		UB100000 to UB10015F	
T	Timer present value		T0 to T255		UW11000 to UW11255
T	Timer set value		T0 to T255		UW13000 to UW13255
C	Counter contact	C0 to C255		UB150000 to UB15015F	
C	Counter present value		C0 to C255		UW16000 to UW16255
C	Counter set value		C0 to C255		UW18000 to UW18255
Z	Index device	Z0 to Z255F	Z0 to Z255	UB067000 to UB06955F	UW6700 to UW6955
F	Special device	F0 to F255F	F0 to F255	UB64000 to UB6655F	UW6400 to UW6655
V	Virtual device	V0 to V255F	V0 to V255	UB061000 to UB06355F	UW06100 to UW06355
L	Link device	L0 to L999F	L0 to L999		UW38000 to UW38999
R	File device	R0 to R3999F	R0 to R3999	UB020000 to UB05999F	UW02000 to UW05999



# Autonics

Sensors & Controllers

[www.autonics.com](http://www.autonics.com)

## Distributor



### Major products

Proximity sensors • Photoelectric sensors • Area sensors • Fiber optic sensors • Door/Door Side sensors • Pressure sensors • Rotary encoders • Sensor controllers • Switching power supply • Temp. controllers • Temperature/Humidity transducers • Power controllers • Recorders • Tachometer/Pulse(Rate) meters • Panel meters • Indicators • Signal convertors • Counters • Timers • Display units • Graphic panel • Stepping Motors & Drivers & Motion controllers

Any proposal for a product improvement and development: [Product@autonics.com](mailto:Product@autonics.com)

### Headquarters

41-5, Yongdang-dong, Yangsan-si, Gyeongnam, 626-847, Korea

### Overseas Business Dept.

Bldg. 402 3rd Fl., Bucheon Techno Park, 193, Yakdae-dong, Wonmi-gu, Bucheon-si, Gyeonggi-do, 420-734, Korea

Tel: 82-32-610-2730 / Fax: 82-32-329-0728 / E-mail: [sales@autonics.com](mailto:sales@autonics.com)

### Brazil

Autonics do Brasil Comercial Importadora Exportadora Ltda

Tel: 55-11-3055-1660 / Fax: 55-11-3055-1661 / E-mail: [vendas@autonics.com.br](mailto:vendas@autonics.com.br)

### China

Autonics electronic(Jiaying) Corporation

Tel: 86-573-8216-1900 / Fax: 86-573-8216-1917 / E-mail: [china@autonics.com](mailto:china@autonics.com)

### India

Autonics Corporation - India Liaison Office

Tel: 91-22-2781-4305 / Fax: 91-22-2781-0538 / E-mail: [india@autonics.com](mailto:india@autonics.com)

### Indonesia

PT. Autonics Indonesia

Tel: 62-21-6586-6740 / Fax: 62-21-6586-6741 / E-mail: [autonics@cbn.net.id](mailto:autonics@cbn.net.id)

### Japan

Autonics Japan Corporation

Tel: 81-3-5730-0568 / Fax: 81-3-5730-0569 / E-mail: [ja@autonicsjp.co.jp](mailto:ja@autonicsjp.co.jp)

### Malaysia

Mal-Autonics Sensor Sdn. Bhd.

Tel: 60-3-7805-7190(Hunting) / Fax: 60-3-7805-7193 / E-mail: [malaysia@autonics.com](mailto:malaysia@autonics.com)

### Mexico

Autonics Mexico Sales Office

Tel: 52-55-5207-0019 / Fax: 52-55-5207-0099 / E-mail: [ventas@autonics.com](mailto:ventas@autonics.com)

### Russia

Autonics Corp. Russia Representative Office

Tel/Fax: 7-495-745-2343 E-mail: [russia@autonics.com](mailto:russia@autonics.com)

### Turkey

Autonics Otomasyon Ticaret Ltd. Sti.

Tel: 90-212-222-0117 (PBX) / Fax: 90-212-222-0108 / E-mail: [info@autonics.com.tr](mailto:info@autonics.com.tr)

### USA

Autonics USA, Inc.

Tel: 1-847-680-8160 / Fax: 1-847-680-8155 / E-mail: [sales@autonicsusa.net](mailto:sales@autonicsusa.net)

### Vietnam

Autonics Vietnam Representative Office

Tel: 84-8-3925-6563 / Fax: 84-8-3925-6564 / E-mail: [vietnam@autonics.com](mailto:vietnam@autonics.com)